



Product Service

Attestation of Conformity

No. N8 13 05 62945 007

Holder of Certificate: **IONIA Co., Ltd.**
163-12, Dodang-Dong, Wonmi-Gu,
Bucheon-City, Gyunggi-Do 420-805
REPUBLIC OF KOREA

Product: **Water treatment equipment
(Alkaline Water Ionizer)**

Model(s): **EN-7P**

Parameters:

Rated input voltage:	230 V~
Rated frequency:	50 Hz
Rated current:	1.0 A
Protection class:	II

Tested according to: EN 60335-1/A14:2010
EN 62233:2008

This Attestation of Conformity is issued on a voluntary basis according to the Low Voltage Directive 2006/95/EC relating to electrical equipment designed for use within certain voltage limits. It confirms that the listed equipment complies with the principal protection requirements of the directive. It refers only to the particular sample submitted for testing and certification. See also notes overleaf.

Test report no.: CPSA01195413



Date, 2013-05-10 (Hyuk-Jun Kwon)



CE After preparation of the necessary technical documentation as well as the EC conformity declaration the required CE marking can be affixed on the product. Other relevant directives have to be observed.



TEST REPORT
IEC/EN 60335-1
Safety of household and similar electrical appliances

Report Reference No.	CPSA01195413
Date of issue.....	2013-05-06
Total number of pages	79 pages
CCA Testing Laboratory	KOREA ES Co., Ltd.
Address	Suwon Cheomdan Venture Valley 715, # 958, Gosaek-dong, Gwonseon-gu, Suwon-si, Gyeonggi-do, Korea
Applicant's name	IONIA Co., Ltd.
Address	163-12, Dodang-Dong, Wonmi-Gu, Bucheon-City, Gyeonggi-Do 420-805, REPUBLIC OF KOREA
Test specification:	
Standard	<input type="checkbox"/> IEC 60335-1:2001 (4. Edition) (incl. Corrigendum 1:2002) + A1:2004 + A2:2006 (incl. Corrigendum 1:2006) and/or <input checked="" type="checkbox"/> EN 60335-1:2002 + A1:2004 + A11:2004 + A12:2006 + A2:2006
Test procedure	CCA
Non-standard test method.....	N/A
Test Report Form No.	IECEN60335_1B
Test Report Form(s) Originator	Nemko AS
Master TRF	Dated 2006-10
Copyright © 2006 IEC System for Conformity Testing and Certification of Electrical Equipment (IECEE), Geneva, Switzerland. All rights reserved.	
This publication may be reproduced in whole or in part for non-commercial purposes as long as the IECEE is acknowledged as copyright owner and source of the material. IECEE takes no responsibility for and will not assume liability for damages resulting from the reader's interpretation of the reproduced material due to its placement and context.	
If this Test Report Form is used by non-IECEE members, the IECEE/IEC logo and the reference to the CB Scheme procedure shall be removed.	
This report is not valid as a CB Test Report unless signed by an approved CB Testing Laboratory and appended to a CB Test Certificate issued by an NCB in accordance with IECEE 02.	
If this Test Report Form is used by non-CCA members, the CIG logo and the reference to the CCA Procedure shall be removed.	
This report is not valid as a CCA Test Report unless signed by an approved CCA Testing Laboratory and appended to a CCA Test Certificate issued by an NCB in accordance with CCA	
Test item description	Alkaline Water Ionizer
Trade Mark	-
Manufacturer	Same as applicant
Model/Type reference.....	EN-7P
Ratings	230 V~, 50 Hz, 1.0 A, Class II



Testing procedure and testing location:	
<input checked="" type="checkbox"/> CCA Testing Laboratory:	KOREA ES Co., Ltd.
Testing location/ address	Suwon Cheomdan Venture Valley 715, # 958, Gosaek-dong, Gwonseon-gu, Suwon-si, Gyeonggi-do, Korea
<input type="checkbox"/> Associated CCA Laboratory:	N/A
Testing location/ address	N/A
Tested by (name + signature)	Seok-Hoon, Wang 
Approved by (+ signature)	Albert Lee 
<input type="checkbox"/> Testing procedure: TMP	N/A
Tested by (name + signature)	N/A
Approved by (+ signature)	N/A
Testing location/ address	N/A
<input type="checkbox"/> Testing procedure: WMT	N/A
Tested by (name + signature)	N/A
Witnessed by (+ signature)	N/A
Approved by (+ signature)	N/A
Testing location/ address	N/A
<input type="checkbox"/> Testing procedure: SMT	N/A
Tested by (name + signature)	N/A
Approved by (+ signature)	N/A
Supervised by (+ signature)	N/A
Testing location/ address	N/A
<input type="checkbox"/> Testing procedure: RMT	N/A
Tested by (name + signature)	N/A
Approved by (+ signature)	N/A
Supervised by (+ signature)	N/A
Testing location/ address	N/A

Summary of testing:

-The presented units were found to be in compliance with the test standards of EN 60335-1:2002 + A1:2004 + A11:2004 + A12:2006 + A2:2006 + A13:2008 + A14:2010 and EN 62233:2008.
-Other safety concerns that are not stated in EN 60335-1 standard were not taken into consideration during the tests.

Tests performed (name of test and test clause):

All clause

Testing location:

KOREA ES Co., Ltd.
Suwon Cheomdan Venture Valley 715, # 958,
Gosaek-dong, Gwonseon-gu, Suwon-si,
Gyeonggi-do, Korea

Summary of compliance with National Differences: N/A

Copy of marking plate:





Test item particulars	:	
Classification of installation and use	:	Portable appliances
Supply Connection.....	:	Y attachment
Protection against electric shock.....	:	Class II
Degree of protection against ingress of water	:	IPX0
Possible test case verdicts:		
- test case does not apply to the test object.....	:	N/A
- test object does meet the requirement	:	P (Pass)
- test object does not meet the requirement	:	F (Fail)
Testing		
Date of receipt of test item	:	2013-03-14
Date (s) of performance of tests	:	2013-03-18 to 2013-04-12
General remarks:		
The test results presented in this report relate only to the object tested. This report shall not be reproduced, except in full, without the written approval of the Issuing testing laboratory. "(See Enclosure #)" refers to additional information appended to the report. "(See appended table)" refers to a table appended to the report.		
Note: This TRF includes EN Group Differences together with National Differences and Special National Conditions, if any. All Differences are located in the Appendix to the main body of this TRF.		
Throughout this report a point is used as the decimal separator.		
Remark1: -APPENDIX No1: Circuit diagram and photographs. -APPENDIX No 2: Amendment A13:2008 to EN 60335-1:2002. -APPENDIX No 3: Amendment A14:2010 to EN 60335-1:2002.		
General product information:		
Main function of this appliance is to change the city water from the water main to either alkaline or acidic water.		

IEC/EN 60335-1			
Clause	Requirement + Test	Result - Remark	Verdict
5	GENERAL CONDITIONS FOR THE TESTS		
	Tests performed according to cl. 5, e.g. nature of supply, sequence of testing, etc.		P
6	CLASSIFICATION		
6.1	Protection against electric shock: Class 0, 0I, I, II, III	Class II	P
6.2	Protection against harmful ingress of water	IPX0	P
7	MARKING AND INSTRUCTIONS		
7.1	Rated voltage or voltage range (V)	230 V	P
	Nature of supply	~	P
	Rated frequency (Hz)	50 Hz	P
	Rated power input (W)		N/A
	Rated current (A)	1.0 A	P
	Manufacturer's or responsible vendor's name, trademark or identification mark	IONIA Co., Ltd.	P
	Model or type reference	EN-7P	P
	Symbol 5172 of IEC 60417, for Class II appliances		P
	IP number, other than IPX0.....	IPX0	N/A
	Symbol IEC 60417-5036, for the enclosure of electrically-operated water valves in external hose-sets for connection of an appliance to the water mains	No such valves	N/A
7.2	Warning for stationary appliances for multiple supply		N/A
	Warning placed in vicinity of terminal cover		N/A
7.3	Range of rated values marked with the lower and upper limits separated by a hyphen		N/A
	Different rated values marked with the values separated by an oblique stroke		N/A
7.4	Appliances adjustable for different rated voltages, the voltage setting is clearly discernible		N/A
7.5	Appliances with more than one rated voltage or one or more rated voltage ranges, marked with rated input or rated current for each rated voltage or range, unless		N/A
	the power input is related to the arithmetic mean value of the rated voltage range		N/A

IEC/EN 60335-1			
Clause	Requirement + Test	Result - Remark	Verdict
	Relation between marking for upper and lower limits of rated power input or rated current and voltage is clear		N/A
7.6	Correct symbols used		P
7.7	Connection diagram fixed to appliances to be connected to more than two supply conductors and appliances for multiple supply		N/A
7.8	Except for type Z attachment, terminals for connection to the supply mains indicated as follows:		-
	- marking of terminals exclusively for the neutral conductor (N/A)		N/A
	- marking of protective earthing terminals (symbol 5019 of IEC 60417)		N/A
	- marking not placed on removable parts		N/A
7.9	Marking or placing of switches which may cause a hazard		N/A
7.10	Indications of switches on stationary appliances and controls on all appliances by use of figures, letters or other visual means	I/O marked on switch body	P
	The figure 0 indicates only OFF position, unless no confusion with the OFF position		N/A
7.11	Indication for direction of adjustment of controls		P
7.12	Instructions for safe use provided		P
	The instructions state that:		-
	- the appliance is not to be used by children or persons with reduced physical, sensory or mental capabilities, or lack of experience and knowledge, unless they have been given supervision or instruction		P
	- children being supervised not to play with the appliance		P
7.12.1	Sufficient details for installation supplied		P
7.12.2	Stationary appliances not fitted with means for disconnection from the supply mains having a contact separation in all poles that provide full disconnection under overvoltage category III, the instructions state that means for disconnection must be incorporated in the fixed wiring in accordance with the wiring rules		N/A

IEC/EN 60335-1			
Clause	Requirement + Test	Result - Remark	Verdict
7.12.3	Insulation of the fixed wiring in contact with parts exceeding 50 K during clause 11; instructions stating that the fixed wiring must be protected		N/A
7.12.4	Instructions for built-in appliances:		
	- dimensions of space		N/A
	- dimensions and position of supporting means		N/A
	- distances between parts and surrounding structure		N/A
	- dimensions of ventilation openings and arrangement		N/A
	- connection to supply mains and interconnection of separate components		N/A
	- allow disconnection of the appliance after installation, by accessible plug or a switch in the fixed wiring, unless		N/A
	a switch complying with 24.3		N/A
7.12.5	Replacement cord instructions, type X attachment with a specially prepared cord		N/A
	Replacement cord instructions, type Y attachment		P
	Replacement cord instructions, type Z attachment		N/A
7.12.6	Caution in the instructions for heating appliances with a non-self-resetting thermal cut-out		N/A
7.12.7	Instructions for fixed appliances stating how the appliance is to be fixed		N/A
7.12.8	Instructions for appliances connected to the water mains:		—
	- max. inlet water pressure (Pa).....:	0.5 MPa	P
	- min. inlet water pressure, if necessary (Pa)	0.07 MPa	P
	Instructions concerning new and old hose-sets for appliances connected to the water mains by detachable hose-sets		P
7.13	Instructions and other texts in an official language	In English	P
7.14	Marking clearly legible and durable		P
7.15	Marking on a main part		P
	Marking clearly discernible from the outside, if necessary after removal of a cover		P
	For portable appliances, cover can be removed or opened without a tool		P



IEC/EN 60335-1			
Clause	Requirement + Test	Result - Remark	Verdict
	For stationary appliances, name, trademark or identification mark and model or type reference visible after installation		N/A
	For fixed appliances, name, trademark or identification mark and model or type reference visible after installation according to the instructions		N/A
	Indications for switches and controls placed on or near the components. Marking not on parts which can be positioned or repositioned in such a way that the marking is misleading		P
7.16	Marking of a possible replaceable thermal link or fuse link clearly visible with regard to replacing the link		P
8	PROTECTION AGAINST ACCESS TO LIVE PARTS		—
8.1	Adequate protection against accidental contact with live parts		P
8.1.1	Requirement applies for all positions, detachable parts removed		P
	Insertion or removal of lamps, protection against contact with live parts of the lamp cap	No lamp	N/A
	Use of test probe B of IEC 61032: no contact with live parts		P
8.1.2	Use of test probe 13 of IEC 61032 through openings in class 0 appliances and class II appliances/ constructions: no contact with live parts		P
	Test probe 13 also applied through openings in earthed metal enclosures having a non-conductive coating: no contact with live parts		N/A
8.1.3	For appliances other than class II, use of test probe 41 of IEC 61032: no contact with live parts of visible glowing heating elements		N/A
8.1.4	Accessible part not considered live if:		—
	- safety extra-low a.c. voltage: peak value not exceeding 42.4 V		N/A
	- safety extra-low d.c. voltage: not exceeding 42.4 V		N/A
	- or separated from live parts by protective impedance		N/A
	If protective impedance: d.c. current not exceeding 2 mA, and		N/A
	a.c. peak value not exceeding 0.7 mA		N/A



IEC/EN 60335-1			
Clause	Requirement + Test	Result - Remark	Verdict
	- for peak values over 42.4 V up to and including 450 V, capacitance not exceeding 0,1 μ F		N/A
	- for peak values over 450 V up to and including 15 kV, discharge not exceeding 45 μ C		N/A
	- for peak values over 15kV, the energy in the discharge not exceeding 350 mJ		N/A
8.1.5	Live parts protected at least by basic insulation before installation or assembly:		—
	- built-in appliances		N/A
	- fixed appliances		N/A
	- appliances delivered in separate units		N/A
8.2	Class II appliances and constructions constructed so that there is adequate protection against accidental contact with basic insulation and metal parts separated from live parts by basic insulation only		P
	Only possible to touch parts separated from live parts by double or reinforced insulation		P
9	STARTING OF MOTOR-OPERATED APPLIANCES		—
	Requirements and tests are specified in part 2 when necessary		N/A
10	POWER INPUT AND CURRENT		-
10.1	Power input at normal operating temperature, rated voltage and normal operation not deviating from rated power input by more than shown in table 1	Not heating, motor-operated. and combined appliance	N/A
	Test for an appliance with one or more rated voltage ranges		N/A
10.2	Current at normal operating temperature, rated voltage and normal operation not deviating from rated current by more than shown in table 2	Not heating, motor-operated. and combined appliance	N/A
	Test for an appliance with one or more rated voltage ranges		N/A
11	HEATING		—
11.1	No excessive temperatures in normal use		P
11.2	Placing and mounting of appliance as described		P
11.3	Temperature rises, other than of windings, determined by thermocouples		P
	Temperature rises of windings determined by resistance method, unless		N/A

IEC/EN 60335-1			
Clause	Requirement + Test	Result - Remark	Verdict
	the windings makes it difficult to make the necessary connections		P
11.4	Heating appliances operated under normal operation at 1.15 times rated power input		N/A
11.5	Motor-operated appliances operated under normal operation at most unfavourable voltage between 0.94 and 1.06 times rated voltage	Tested at 216.2 V and 243.8 V (Not heating, motor-operated. and combined appliance)	P
11.6	Combined appliances operated under normal operation at most unfavourable voltage between 0.94 and 1.06 times rated voltage		N/A
11.7	Operation duration corresponding to the most unfavourable conditions of normal use		P
11.8	Temperature rises not exceeding values in table 3	(see appended tables)	P
	Sealing compound does not flow out		P
	Protective devices do not operate, except		P
	components in protective electronic circuits tested for the number of cycles specified in 24.1.4		N/A
13	LEAKAGE CURRENT AND ELECTRIC STRENGTH AT OPERATING TEMPERATURE		—
13.1	Leakage current not excessive and electric strength adequate		P
	Heating appliances operated at 1.15 times rated power input	Not heating appliances	N/A
	Motor-operated appliances and combined appliances supplied at 1.06 times rated voltage	Test at 243.8 V	P
	Protective impedance and radio interference filters disconnected before carrying out the tests		N/A
13.2	Leakage current measured by means of the circuit described in figure 4 of IEC 60990		P
	Leakage current measurements	(see appended table)	P
13.3	The appliance is disconnected from the supply		P
	Electric strength tests according to table 4	(see appended table)	P
	No breakdown during the tests		P
14	TRANSIENT OVERVOLTAGES		—
	Appliances withstand the transient overvoltages to which they may be subjected		N/A

IEC/EN 60335-1			
Clause	Requirement + Test	Result - Remark	Verdict
	Clearances having a value less than specified in table 16 subjected to an impulse voltage test, the test voltage specified in table 6		N/A
	No flashover during the test, unless of functional insulation		N/A
	In case of flashover of functional insulation, the appliance complies with clause 19 with the clearance short circuited		N/A
15	MOISTURE RESISTANCE		—
15.1	Enclosure provides the degree of moisture protection according to classification of the appliance	IPX0	N/A
	Compliance checked as specified in 15.1.1, taking into account 15.1.2, followed by the electric strength test of 16.3		N/A
	No trace of water on insulation which can result in a reduction of clearances and creepage distances below values specified in clause 29		N/A
15.1.1	Appliances, other than IPX0, subjected to tests as specified in IEC 60529		—
	Water valves in external hoses for connection of an appliance to the water mains tested as specified for IPX7 appliances		N/A
15.1.2	Hand-held appliance turned continuously through the most unfavourable positions during the test		N/A
	Built-in appliances installed according to the instructions		N/A
	Appliances placed or used on the floor or table placed on a horizontal unperforated support		N/A
	Appliances normally fixed to a wall and appliances with pins for insertion into socket-outlets are mounted on a wooden board		N/A
	For IPX3 appliances, the base of wall mounted appliances is placed at the same level as the pivot axis of the oscillating tube		N/A
	For IPX4 appliances, the horizontal centre line of the appliance is aligned with the pivot axis of the oscillating tube		N/A
	However, for appliances normally used on the floor or table, the movement is limited to two times 90° for a period of 5 min, the support being placed at the level of the pivot axis of the oscillating tube		N/A

IEC/EN 60335-1			
Clause	Requirement + Test	Result - Remark	Verdict
	Appliances normally fixed to a ceiling are mounted underneath a horizontal unperforated support, the pivot axis of the oscillating tube located at the level of the underside of the support		N/A
	For IPX4 appliances, the movement of the tube is limited to two times 90° from the vertical for a period of 5 min		N/A
	Wall-mounted appliances, take into account the distance to the floor stated in the instructions		N/A
	Appliances with type X attachment fitted with a flexible cord as described		N/A
	Detachable parts tested as specified		N/A
15.2	Spillage of liquid does not affect the electrical insulation		N/A
	Appliances with type X attachment fitted with a flexible cord as described		N/A
	Appliances incorporating an appliance inlet tested with or without an connector, whichever is most unfavourable		N/A
	Detachable parts removed		N/A
	Overfilling test with additional amount of water, over a period of 1 min (l)		N/A
	The appliance withstands the electric strength test of 16.3		N/A
	No trace of water on insulation that can result in a reduction of clearances and creepage distances below values specified in clause 29		N/A
15.3	Appliances proof against humid conditions		P
	Humidity test for 48 h in a humidity cabinet	48 hr, 93 %, 30 °C	P
	The appliance withstands the tests of clause 16	No breakdown	P
16	LEAKAGE CURRENT AND ELECTRIC STRENGTH		—
16.1	Leakage current not excessive and electric strength adequate		P
	Protective impedance disconnected from live parts before carrying out the tests		N/A
16.2	Single-phase appliances: test voltage 1.06 times rated voltage	Tested at 243.8 V	P
	Three-phase appliances: test voltage 1.06 times rated voltage divided by $\sqrt{3}$	Not three-phase appliances	N/A

IEC/EN 60335-1			
Clause	Requirement + Test	Result - Remark	Verdict
	Leakage current measurements	(see appended table)	P
16.3	Electric strength tests according to table 7	(see appended table)	P
	No breakdown during the tests		P
17	OVERLOAD PROTECTION OF TRANSFORMERS AND ASSOCIATED CIRCUITS		
	No excessive temperatures in transformer or associated circuits in event of short-circuits likely to occur in normal use	(see appended table)	N/A
	Appliance supplied with 1.06 or 0.94 times rated voltage and the most unfavourable short-circuit or overload likely to occur in normal use applied		N/A
	Temperature rise of insulation of the conductors of safety extra-low voltage circuits not exceeding the relevant value specified in table 3 by more than 15 K		N/A
	Temperature of the winding not exceeding the value specified in table 8,		N/A
	however limits do not apply to fail-safe transformers complying with sub-clause 15.5 of IEC 61558-1		N/A
18	ENDURANCE		
	Requirements and tests are specified in part 2 when necessary		N/A
19	ABNORMAL OPERATION		
19.1	The risk of fire or mechanical damage under abnormal or careless operation obviated		P
	Electronic circuits so designed and applied that a fault will not render the appliance unsafe		P
	Appliances incorporating contactors or relays subjected to the test of 19.14, being carried out before the tests of 19.11		P
19.2	Test of appliance with heating elements with restricted heat dissipation; test voltage (V): power input of 0.85 times rated power input.....:	No heating elements	N/A
19.3	Test of 19.2 repeated; test voltage (V): power input of 1.24 times rated power input.....:		N/A
19.4	Test conditions as in cl. 11, any control limiting the temperature during tests of cl. 11 short-circuited		N/A
19.5	Test of 19.4 repeated on Class 0I and I appliances with tubular sheathed or embedded heating elements. No short-circuiting, but one end of the element connected to the elements sheath		N/A

IEC/EN 60335-1			
Clause	Requirement + Test	Result - Remark	Verdict
	The test repeated with reversed polarity and the other end of the heating element connected to the sheath		N/A
	The test is not carried out on appliances intended to be permanently connected to fixed wiring and on appliances where an all-pole disconnection occurs during the test of 19.4		N/A
19.6	Appliances with PTC heating elements tested at rated voltage, establishing steady conditions		N/A
	The working voltage of the PTC heating element is increased by 5% and the appliance is operated until steady conditions are re-established. The voltage is then increased in similar steps until 1.5 times working voltage or until the PTC heating element ruptures		N/A
19.7	Stalling test by locking the rotor if the locked rotor torque is smaller than the full load torque or locking moving parts of other appliances		N/A
	Locked rotor, motor capacitors open-circuited or short-circuited, if required		N/A
	Locked rotor, capacitors open-circuited one at a time		N/A
	Test repeated with capacitors short-circuited one at a time, if required		N/A
	Appliances with timer or programmer supplied with rated voltage for each of the tests, for a period equal to the maximum period allowed		N/A
	Other appliances supplied with rated voltage for a period as specified		N/A
	Winding temperatures not exceeding values specified in table 8		N/A
19.8	Three-phase motors operated at rated voltage with one phase disconnected		N/A
19.9	Running overload test on appliances incorporating motors intended to be remotely or automatically controlled or liable to be operated continuously		N/A
	Winding temperatures not exceeding values as specified		N/A
19.10	Series motor operated at 1.3 times rated voltage for 1 min		N/A
	During the test, parts not being ejected from the appliance		N/A

IEC/EN 60335-1			
Clause	Requirement + Test	Result - Remark	Verdict
19.11	Electronic circuits, compliance checked by evaluation of the fault conditions specified in 19.11.2 for all circuits or parts of circuits, unless they comply with the conditions specified in 19.11.1		P
	Appliances incorporating a protective electronic circuit subjected to the tests of 19.11.3 and 19.11.4		N/A
	Appliances having a switch with an off position obtained by electronic disconnection, or a switch placing the appliance in a stand-by mode, subjected to the tests of 19.11.4		N/A
	Appliances incorporating an electronic circuit that relies upon a programmable component to function correctly, subjected to the test of 19.11.4.8		N/A
19.11.1	Before applying the fault conditions a) to f) in 19.11.2, it is checked if circuits or parts of circuit meet both of the following conditions:		—
	- the electronic circuit is a low-power circuit, that is, the maximum power at low-power points does not exceed 15 W according to the tests specified		N/A
	- the protection against electric shock, fire hazard, mechanical hazard or dangerous malfunction in other parts of the appliance does not rely on the correct functioning of the electronic circuit		N/A
19.11.2	Fault conditions applied one at a time, the appliance operated under conditions specified in cl. 11, but supplied at rated voltage, the duration of the tests as specified:		—
	a) short circuit of functional insulation if clearances or creepage distances are less than the values specified in 29		N/A
	b) open circuit at the terminals of any component		P
	c) short circuit of capacitors, unless they comply with IEC 60384-14		N/A
	d) short circuit of any two terminals of an electronic component, other than integrated circuits. This fault condition is not applied between the two circuits of an optocoupler		P
	e) failure of triacs in the diode mode		N/A
	f) failure of an integrated circuit		P
	g) failure of an electronic power switching device		N/A
19.11.3	If the appliance incorporates a protective electronic circuit which operates to ensure compliance with clause 19, the relevant test is repeated with a single fault simulated, as indicated in a) to f) of 19.11.2		N/A

IEC/EN 60335-1			
Clause	Requirement + Test	Result - Remark	Verdict
	During and after each test the following is checked:		
	- the temperature rise of the windings do not exceed the values specified in table 8		N/A
	- the appliance complies with the conditions specified in 19.13		N/A
	- any current flowing through protective impedance not exceeding the limits specified in 8.1.4		N/A
	If a conductor of a printed board becomes open-circuited, the appliance is considered to have withstood the particular test, provided all three of the following conditions are met:		N/A
	- the material of the printed circuit board withstands the burning test of annex E		N/A
	- any loosened conductor does not reduce the clearances or creepage distances between live parts and accessible metal parts below the values specified in cl. 29		N/A
	- the appliance withstands the tests of 19.11.2 with open-circuited conductor bridged		N/A
19.11.4	Appliances having a device with an off position obtained by electronic disconnection, or		N/A
	a device that can be placed in the stand-by mode,		N/A
	subjected to the tests of 19.11.4.1 to 19.11.4.7		N/A
	Appliances incorporating a protective electronic circuit subjected to the tests of 19.11.4.1 to 19.11.4.7, except that		N/A
	appliances operated for 30 s or 5 min during the test of 19.7 are not subjected to the tests for electromagnetic phenomena.		N/A
19.11.4.1	The appliance is subjected to electrostatic discharges in accordance with IEC 61000-4-2, test level 4		N/A
19.11.4.2	The appliance is subjected to radiated fields in accordance with IEC 61000-4-3, test level 3		N/A
19.11.4.3	The appliance is subjected to fast transient bursts in accordance with IEC 61000-4-4, test level 3 or 4 as specified		N/A
19.11.4.4	The power supply terminals of the appliance subjected to voltage surges in accordance with IEC 61000-4-5, test level 3 or 4 as specified		N/A
	Earthed heating elements in class I appliances disconnected		N/A

IEC/EN 60335-1			
Clause	Requirement + Test	Result - Remark	Verdict
19.11.4.5	The appliance is subjected to injected currents in accordance with IEC 61000-4-6, test level 3		N/A
19.11.4.6	The appliance is subjected to the Class 3 voltage dips and interruptions in accordance with IEC 61000-4-11		N/A
19.11.4.7	The appliance is subjected to mains signals in accordance with IEC 61000-4-13, test level class 2		N/A
19.11.4.8	The appliance is supplied at rated voltage and operated under normal operation. After 60s the power supply is reduces to a level such that the appliance ceases to respond or a programmable component cease to operate.		N/A
	The appliance continues to operate normally or requires a manual operation to restart		N/A
19.12	If the safety of the appliance for any of the fault conditions specified in 19.11.2 depends on the operation of a miniature fuse-link complying with IEC 60127, the test is repeated, measuring the current flowing through the fuse-link; measured current (A); rated current of the fuse-link (A)		P
19.13	During the tests the appliance does not emit flames, molten metal, poisonous or ignitable gas in hazardous amounts		P
	Temperature rises not exceeding the values shown in table 9	(see appended table)	P
	Compliance with cl. 8 not impaired		P
	If the appliance can still be operated it complies with 20.2		P
	Insulation, other than of class III appliance, withstand the electric strength test of 16.3, the test voltage specified in table 4:		P
	- basic insulation		N/A
	- supplementary insulation		N/A
	- reinforced insulation	3000 V	P
	After operation or interruption of a control, clearances and creepage distances across the functional insulation withstanding the electric strength test of 16.3. the test voltage being twice the working voltage		P
	The appliance does not undergo a dangerous malfunction, and		P
	no failure of protective electronic circuits, if the appliance is still operable		N/A

IEC/EN 60335-1			
Clause	Requirement + Test	Result - Remark	Verdict
	Appliances tested with an electronic switch in the off position, or in the stand-by mode:		
	- do not become operational, or		N/A
	- if they become operational, do not result in a dangerous malfunction during or after the tests of 19.11.4		N/A
19.14	Appliances operated under the conditions of Clause 11. Contactors or relays contacts operating under the conditions of clause 11 short-circuited		P
20	STABILITY AND MECHANICAL HAZARDS		
20.1	Adequate stability		P
	Tilting test through an angle of 10° (appliance placed on an inclined plane/horizontal plane); appliance does not overturn	Not overturn	P
	Tilting test repeated on appliances with heating elements, angle of inclination increased to 15°		N/A
	Possible heating test in overturned position; temperature rise does not exceed values shown in table 9		N/A
20.2	Moving parts adequately arranged or enclosed as to provide protection against personal injury	No moving parts	N/A
	Protective enclosures, guards and similar parts are non-detachable		N/A
	Adequate mechanical strength and fixing of protective enclosures		N/A
	Self-resetting thermal cut-outs and overcurrent protective devices not causing a hazard, by unexpected reclosure		N/A
	Not possible to touch dangerous moving parts with test probe		N/A
21	MECHANICAL STRENGTH		
21.1	Appliance has adequate mechanical strength and is constructed as to withstand rough handling		P
	Checked by applying blows to the appliance in accordance with test Ehb of IEC 60068-2-75, spring hammer test, impact energy 0,5 J		P
	If necessary, supplementary or reinforced insulation subjected to the electric strength test of 16.3		P
	If necessary, repetition of groups of three blows on a new sample		N/A

IEC/EN 60335-1			
Clause	Requirement + Test	Result - Remark	Verdict
21.2	Accessible parts of solid insulation having strength to prevent penetration by sharp implements		P
	The insulation is tested as specified, unless		N/A
	the thickness of supplementary insulation is at least 1 mm and reinforced insulation is at least 2 mm		P
22	CONSTRUCTION		—
22.1	Appliance marked with the first numeral of the IP system, relevant requirements of IEC 60529 are fulfilled		N/A
22.2	Stationary appliance: means to provide all-pole disconnection from the supply provided, the following means being available:		—
	- a supply cord fitted with a plug		P
	- a switch complying with 24.3		N/A
	- a statement in the instruction sheet that a disconnection incorporated in the fixed wiring is to be provided		N/A
	- an appliance inlet		N/A
	Single-pole switches and single-pole protective devices for the disconnection of heating elements in single-phase, permanently connected class 01 and class I appliances, connected to the phase conductor		N/A
22.3	Appliance provided with pins: no undue strain on socket-outlets		N/A
	Applied torque not exceeding 0.25 Nm		N/A
	Pull force of 50N to each pin after the appliance has been placed in the heating cabinet; when cooled to room temperature the pins are not displaced by more than 1mm		N/A
	Each pin subjected to a torque of 0.4Nm; the pins are not rotating unless rotating does not impair compliance with the standard		N/A
22.4	Appliance for heating liquids and appliance causing undue vibration not provided with pins for insertion into socket-outlets		N/A
22.5	No risk of electric shock when touching the pins of the plug, for appliances having a capacitor with rated capacitance exceeding 0,1µF, the appliance being disconnected from the supply at the instant of voltage peak		P
22.6	Electrical insulation not affected by condensing water or leaking liquid	No trace of liquid on windings	P

IEC/EN 60335-1			
Clause	Requirement + Test	Result - Remark	Verdict
	Electrical insulation of Class II appliances not affected in case of a hose rupture or seal leak		P
22.7	Adequate safeguards against the risk of excessive pressure in appliances provided with steam-producing devices		N/A
22.8	Electrical connections not subject to pulling during cleaning of compartments to which access can be gained without the aid of a tool, and that are likely to be cleaned in normal use		N/A
22.9	Insulation, internal wiring, windings, commutators and slip rings not exposed to oil, grease or similar substances		P
	Adequate insulating properties of oil or grease to which insulation is exposed		N/A
22.10	Not possible to reset voltage-maintained non-self-resetting thermal cut-outs by the operation of an automatic switching device incorporated within the appliance		N/A
	Non-self resetting thermal motor protectors have a trip-free action, unless		N/A
	they are voltage maintained		N/A
	Location or protection of reset buttons of non-self-resetting controls is so that accidental resetting is unlikely		N/A
22.11	Reliable fixing of non-detachable parts that provide the necessary degree of protection against electric shock, moisture or contact with moving parts		P
	Obvious locked position of snap-in devices used for fixing such parts		N/A
	No deterioration of the fixing properties of snap-in devices used in parts that are likely to be removed during installation or servicing		N/A
	Tests as described	Push: 50 N, Pull: 50 N	P
22.12	Handles, knobs etc. fixed in a reliable manner		P
	Fixing in wrong position of handles, knobs etc. indicating position of switches or similar components not possible		P
	Axial force 15 N/A applied to parts, the shape being so that an axial pull is unlikely to be applied		N/A
	Axial force 30 N/A applied to parts, the shape being so that an axial pull is likely to be applied		P



IEC/EN 60335-1			
Clause	Requirement + Test	Result - Remark	Verdict
22.13	Unlikely that handles, when gripped as in normal use, make the operators hand touch parts having a temperature rise exceeding the value specified for handles which are held for short periods only		N/A
22.14	No ragged or sharp edges creating a hazard for the user in normal use, or during user maintenance		P
	No exposed pointed ends of self tapping screws etc., liable to be touched by the user in normal use or during user maintenance		P
22.15	Storage hooks and the like for flexible cords smooth and well rounded		N/A
22.16	Automatic cord reels cause no undue abrasion or damage to the sheath of the flexible cord, no breakage of conductors strands, no undue wear of contacts		N/A
	Cord reel tested with 6000 operations, as specified		N/A
	Electric strength test of 16.3, voltage of 1000 V applied		N/A
22.17	Spacers not removable from the outside by hand or by means of a screwdriver or a spanner		N/A
22.18	Current-carrying parts and other metal parts resistant to corrosion under normal conditions of use		P
22.19	Driving belts not used as electrical insulation	No such belts	N/A
22.20	Direct contact between live parts and thermal insulation effectively prevented, unless material used is non-corrosive, non-hygroscopic and non-combustible		N/A
	Compliance is checked by inspection and, if necessary, by appropriate test		N/A
22.21	Wood, cotton, silk, ordinary paper and fibrous or hygroscopic material not used as insulation, unless impregnated		P
	This requirement does not apply to magnesium oxide and mineral ceramic fibres used for the electrical insulation of heating elements		N/A
22.22	Appliances not containing asbestos		P
22.23	Oils containing polychlorinated biphenyl (PCB) not used		P
22.24	Bare heating elements adequately supported	No heating element	N/A
	In case of rupture, the heating conductor is unlikely to come in contact with accessible metal parts		N/A



IEC/EN 60335-1			
Clause	Requirement + Test	Result - Remark	Verdict
22.25	Sagging heating conductors cannot come into contact with accessible metal parts	No heating element	N/A
22.26	The insulation between parts operating at safety extra-low voltage and other live parts complies with the requirements for double or reinforced insulation		P
22.27	Parts connected by protective impedance separated by double or reinforced insulation		N/A
22.28	Metal parts of Class II appliances conductively connected to gas pipes or in contact with water: separated from live parts by double or reinforced insulation		P
22.29	Class II appliances permanently connected to fixed wiring so constructed that the required degree of access to live parts is maintained after installation		N/A
22.30	Parts serving as supplementary or reinforced insulation fixed so that they cannot be removed without being seriously damaged, or		P
	so constructed that they cannot be replaced in an incorrect position, and so that if they are omitted, the appliance is rendered inoperable or manifestly incomplete		P
22.31	Clearances and creepage distances over supplementary and reinforced insulation not reduced below values specified in clause 29 as a result of wear		P
	Clearances and creepage distances between live parts and accessible parts not reduced below values for supplementary insulation, if wires, screws etc. become loose		P
22.32	Supplementary and reinforced insulation designed or protected against deposition of dirt or dust		P
	Supplementary insulation of natural or synthetic rubber resistant to ageing, or arranged and dimensioned so that creepage distances are not reduced below values specified in 29.2		N/A
	Ceramic material not tightly sintered, similar material or beads alone not used as supplementary or reinforced insulation		N/A
	Oxygen bomb test at 70 °C for 96 h and 16 h at room temperature		N/A
	Insulating material in which heating conductors are embedded is considered to be basic insulation and not reinforced insulation		N/A



IEC/EN 60335-1			
Clause	Requirement + Test	Result - Remark	Verdict
22.33	Conductive liquids that are or may become accessible in normal use are not in direct contact with live parts		P
	Electrodes not used for heating liquids		N/A
	For class II constructions, conductive liquids that are or may become accessible in normal use, not in direct contact with basic or reinforced insulation		P
	For class II constructions, conductive liquids which are in contact with live parts, not in direct contact with reinforced insulation		N/A
22.34	Shafts of operating knobs, handles, levers etc. not live, unless the shaft is not accessible when the part is removed		P
22.35	Handles, levers and knobs, held or actuated in normal use, not becoming live in the event of a failure of basic insulation		P
	Such parts being of metal, and their shafts or fixings are likely to become live in the event of a failure of basic insulation, are either adequately covered by insulation material or their accessible parts are separated from their shafts or fixings by supplementary insulation		N/A
	This requirement does not apply to handles, levers and knobs on stationary appliances other than those of electrical components, provided they are either reliably connected to an earthing terminal or earthing contact, or separated from live parts by earthed metal		N/A
22.36	Handles continuously held in the hand in normal use are so constructed that when gripped as in normal use, the operators hand is not likely to touch metal parts, unless they are separated from live parts by double or reinforced insulation		N/A
22.37	Capacitors in Class II appliances not connected to accessible metal parts, unless complying with 22.42		P
	Metal casings of capacitors in Class II appliances separated from accessible metal parts by supplementary insulation, unless complying with 22.42		N/A
22.38	Capacitors not connected between the contacts of a thermal cut-out		P
22.39	Lamp holders used only for the connection of lamps		N/A

IEC/EN 60335-1			
Clause	Requirement + Test	Result - Remark	Verdict
22.40	Motor-operated appliances and combined appliances intended to be moved while in operation, or having accessible moving parts, fitted with a switch to control the motor. The actuating member of the switch being easily visible and accessible		N/A
	Unless the appliance can operate continuously, automatically or remotely without giving rise to a hazard, appliances for remote operation being fitted with a switch. The actuating member of the switch being easily visible and accessible.		N/A
22.41	No components, other than lamps, containing mercury		P
22.42	Protective impedance consisting of at least two separate components		N/A
	Values specified in 8.1.4 not exceeded if any one of the components are short-circuited or open-circuited		N/A
22.43	Appliances adjustable for different voltages, accidental changing of the setting of the voltage unlikely to occur		N/A
22.44	Appliances shall not have an enclosure that is shaped or decorated like a toy		P
22.45	When air is used as reinforced insulation, clearances not reduced below the values specified in 29.1.4 due to deformation as a result of an external force applied to the enclosure		P
22.46	Software used in protective electronic circuits is software class B or C		N/A
22.47	Appliances connected to the water mains withstand the water pressure expected in normal use	1.2 MPa, 5 min	P
	No leakage from any part, including any inlet water hose		P
22.48	Appliances connected to the water mains constructed to prevent backsiphonage of non-potable water		P
22.49	For remote operation, the duration of operation shall be set before the appliance can be started, unless		N/A
	the appliance switches off automatically or can operate continuously without hazard		N/A
22.50	Controls incorporated in the appliance take priority over controls actuated by remote operation		N/A



IEC/EN 60335-1			
Clause	Requirement + Test	Result - Remark	Verdict
22.51	A control on the appliance being manually adjusted to the setting for remote operation before the appliance can be operated in this mode		N/A
	There is a visual indication showing that the appliance is adjusted for remote operation		N/A
	Manual setting and visual indication not necessary on appliances that can operate as follows, without giving rise to a hazard:		N/A
	- operate continuously,		N/A
	- operate automatically, or		N/A
	- be operated remotely		N/A
22.52	Socket-outlets on appliances accessible to the user in accordance with the socket-outlet system used in the country in which the appliance is sold		N/A
23	INTERNAL WIRING		—
23.1	Wireways smooth and free from sharp edges		P
	Wires protected against contact with burrs, cooling fins etc.		P
	Wire holes in metal well rounded or provided with bushings		N/A
	Wiring effectively prevented from coming into contact with moving parts	No moving part	N/A
23.2	Beads etc. on live wires cannot change their position, and are not resting on sharp edges or corners		N/A
	Beads inside flexible metal conduits contained within an insulating sleeve		N/A
23.3	Electrical connections and internal conductors movable relatively to each other not exposed to undue stress		N/A
	Flexible metallic tubes not causing damage to insulation of conductors		N/A
	Open-coil springs not used		N/A
	Adequate insulating lining provided inside a coiled spring, the turns of which touch one another		N/A
	No damage after 10 000 flexings for conductors flexed during normal use or 100 flexings for conductors flexed during user maintenance		N/A
	Electric strength test, 1000 V between live parts and accessible metal parts		N/A
23.4	Bare internal wiring sufficiently rigid and fixed		N/A



IEC/EN 60335-1			
Clause	Requirement + Test	Result - Remark	Verdict
23.5	The insulation of internal wiring withstanding the electrical stress likely to occur in normal use		P
	No breakdown when a voltage of 2000 V is applied for 15 min between the conductor and metal foil wrapped around the insulation		P
23.6	Sleeving used as supplementary insulation on internal wiring retained in position by positive means		N/A
23.7	The colour combination green/yellow used only for earthing conductors	Class II appliance	N/A
23.8	Aluminium wires not used for internal wiring	No aluminium wires	P
23.9	No lead-tin soldering of stranded conductors where they are subject to contact pressure, unless	No lead-tin soldering	P
	clamping means so constructed that there is no risk of bad contact due to cold flow of the solder		N/A
23.10	The insulation and sheath of internal wiring, incorporated in external hoses for the connection of an appliance to the water mains, at least equivalent to that of light polyvinyl chloride sheathed flexible cord (60227 IEC 52)		N/A
24	COMPONENTS		—
24.1	Components comply with safety requirements in relevant IEC standards		P
	List of components	(see appended table)	P
	Components not tested and found to comply with relevant IEC standard for the number of cycles specified are tested in accordance with 24.1.1 to 24.1.9		P
	Components not tested and found to comply with relevant IEC standard, components not marked or not used in accordance with its marking, tested under the conditions occurring in the appliance		P
	Lampholders and starterholders not being tested and found to comply with the relevant IEC standard, tested as a part of the appliance and additionally according to the gauging and interchangeability requirements of the relevant IEC standard	No lampholders and starterholders	N/A
24.1.1	Capacitors likely to be permanently subjected to the supply voltage and used for radio interference suppression or for voltage dividing, complying with IEC 60384-14, or		P
	tested according to annex F		N/A



IEC/EN 60335-1			
Clause	Requirement + Test	Result - Remark	Verdict
24.1.2	Safety isolating transformers complying with IEC 61558-2-6, or		N/A
	tested according to annex G		N/A
24.1.3	Switches complying with IEC 61058-1, the number of cycles of operation being at least 10 000, or	Approved switch	P
	tested according to annex H		N/A
	If the switch operates a relay or contactor, the complete switching system is subjected to the test		N/A
24.1.4	Automatic controls complying with IEC 60730-1 with relevant part 2. The number of cycles of operation being:		
	- thermostats: 10 000		N/A
	- temperature limiters: 1 000		N/A
	- self-resetting thermal cut-outs: 300		N/A
	- voltage maintained non-self-resetting thermal cut-outs: 1000		N/A
	- other non-self-resetting thermal cut-outs: 30		N/A
	- timers: 3 000		N/A
	- energy regulators: 10 000		N/A
	Thermal motor protectors are tested in combination with their motor under the conditions specified in Annex D		N/A
	For water valves containing live parts and that are incorporated in external hoses for connection of an appliance to the water mains, the degree of protection declared for subclause 6.5.2 of IEC 60730-2-8 is IPX7		N/A
24.1.5	Appliance couplers complying with IEC 60320-1		N/A
	However, appliances classified higher than IPX0, the appliance couplers complying with IEC 60320-2-3		N/A
	Interconnection couplers complying with IEC 60320-2-2		N/A
24.1.6	Small lamp holders similar to E10 lampholders complying with IEC 60238, the requirements for E10 lampholders being applicable		N/A
24.1.7	If the remote operation of the appliance is via a telecommunication network, the relevant standard for the telecommunication interface circuitry in the appliance is IEC 62151		N/A

IEC/EN 60335-1			
Clause	Requirement + Test	Result - Remark	Verdict
24.1.8	The relevant standard for thermal links is IEC 60691. Thermal links not complying with IEC 60691 are considered to be an intentionally weak part for the purposes of Clause 19		N/A
24.1.9	Relays, other than motor starting relays, tested as part of the appliance		P
	They are also tested in accordance with Clause 17 of IEC 60730-1, the number of operations in 24.1.4 selected according to the relay function in the appliance		P
24.2	No switches or automatic controls in flexible cords	No such device	P
	No devices causing the protective device in the fixed wiring to operate in the event of a fault in the appliance	No such device	P
	No thermal cut-outs that can be reset by soldering		P
24.3	Switches intended for all-pole disconnection of stationary appliances are directly connected to the supply terminals and having a contact separation in all poles, providing full disconnection under overvoltage category III conditions		N/A
24.4	Plugs and socket-outlets for extra-low voltage circuits and heating elements, not interchangeable with plugs and socket-outlets listed in IEC 60083 or IEC 60906-1 or with connectors and appliance inlets complying with the standard sheets of IEC 60320-1		N/A
24.5	Capacitors in auxiliary windings of motors marked with their rated voltage and capacitance and used accordingly		N/A
	Voltage across capacitors in series with a motor winding does not exceed 1,1 times rated voltage, when the appliance is supplied at 1,1 times rated voltage under minimum load		N/A
24.6	Working voltage of motors connected to the supply mains and having basic insulation that is inadequate for the rated voltage of the appliance, not exceeding 42V		N/A
	In addition, the motors are complying with the requirements of Annex I		N/A
24.7	Hose-sets for connection of appliances to the water mains, complying with IEC 61770 and supplied with the appliance		P
25	SUPPLY CONNECTION AND EXTERNAL FLEXIBLE CORDS		—

IEC/EN 60335-1			
Clause	Requirement + Test	Result - Remark	Verdict
25.1	Appliance not intended for permanent connection to fixed wiring, means for connection to the supply:		P
	- supply cord fitted with a plug		P
	- an appliance inlet having at least the same degree of protection against moisture as required for the appliance		N/A
	- pins for insertion into socket-outlets		N/A
25.2	Appliance not provided with more than one means of connection to the supply mains		P
	Stationary appliance for multiple supply may be provided with more than one means of connection, provided electric strength test of 1250 V for 1 min between each means of connection causes no breakdown	Not multiple supply	N/A
25.3	Connection of supply conductors for appliance intended to be permanently connected to fixed wiring possible after the appliance has been fixed to its support		N/A
	Appliance provided with a set of terminals for the connection of cables or fixed wiring, cross-sectional areas specified in 26.6		N/A
	Appliance provided with a set of terminals allowing the connection of a flexible cord		N/A
	Appliance provided with a set of supply leads accommodated in a suitable compartment		N/A
	Appliance provided with a set of terminals and cable entries, conduit entries, knock-outs or glands, allowing connection of appropriate type of cable or conduit		N/A
25.4	Cable and conduit entries, rated current of appliance not exceeding 16 A, dimension according to table 10		N/A
	Introduction of conduit or cable does not reduce clearances or creepage distances below values specified in 29		N/A
25.5	Method for assemble supply cord with the appliance:		N/A
	- type X attachment		N/A
	- type Y attachment		P
	- type Z attachment, if allowed in part 2		N/A
	Type X attachment, other than those with a specially prepared cord, not used for flat twin tinsel cords		N/A



IEC/EN 60335-1			
Clause	Requirement + Test	Result - Remark	Verdict
25.6	Plugs fitted with only one flexible cord		P
25.7	Supply cords being one of the following types:		P
	- rubber sheathed (at least 60245 IEC 53)		N/A
	- polychloroprene sheathed (at least 60245 IEC 57)		N/A
	- cross-linked polyvinyl chloride sheathed (at least 60245 IEC 87)		N/A
	Polyvinyl chloride sheathed: Not used if they are likely to touch metal parts having a temperature rise exceeding 75K during the test of Clause 11.		N/A
	- light polyvinyl chloride sheathed cord (at least 60227 IEC 52), appliances not exceeding 3 kg	H03VVH2-F	P
	- ordinary polyvinyl chloride sheathed cord (at least 60227 IEC 53), other appliances		N/A
	Heat resistant polyvinyl chloride sheathed: Not used for type X attachment other than specially prepared cords.		N/A
	- Heat-resistant light polyvinyl chloride sheathed cord (at least 60227 IEC 56), appliances not exceeding 3 kg		N/A
	- heat-resistant polyvinyl chloride sheathed cord (60227 IEC 57), other appliances		N/A
25.8	Nominal cross-sectional area of supply cords according to table 11; rated current (A); cross-sectional area (mm ²)	1.0 A, 0.75 mm ²	P
25.9	Supply cord not in contact with sharp points or edges		P
25.10	Green/yellow core for earthing purposes in Class I appliance		N/A
25.11	Conductors of supply cords not consolidated by lead-tin soldering where they are subject to contact pressure, unless		P
	clamping means so constructed that there is no risk of bad contacts due to cold flow of the solder		N/A
25.12	Moulding the cord to part of the enclosure does not damage the insulation of the supply cord		P
25.13	Inlet opening so shaped as to prevent damage to the supply cord		P
	Unless the enclosure at the inlet opening is of insulation material, a non-detachable lining or bushing complying with 29.3 for supplementary insulation provided		N/A

IEC/EN 60335-1			
Clause	Requirement + Test	Result - Remark	Verdict
	If unsheathed supply cord, a similar additional bushing or lining is required, unless		N/A
	the appliance is class 0		N/A
25.14	Supply cords adequately protected against excessive flexing		N/A
	Flexing test:		
	- applied force (N/A)		N/A
	- number of flexings.....		N/A
	The test does not result in:		N/A
	- short circuit between the conductors		N/A
	- breakage of more than 10% of the strands of any conductor		N/A
	- separation of the conductor from its terminal		N/A
	- loosening of any cord guard		N/A
	- damage, within the meaning of the standard, to the cord or the cord guard		N/A
	- broken strands piercing the insulation and becoming accessible		N/A
25.15	Conductors of the supply cord relieved from strain, twisting and abrasion by use of cord anchorage		P
	The cord cannot be pushed into the appliance to such an extent that the cord or internal parts of the appliance can be damaged		P
	Pull and torque test of supply cord, values shown in table 10: pull (N/A); torque (not on automatic cord reel) (Nm)	100 N, 0.35 Nm	P
	Max. 2 mm displacement of the cord, and conductors not moved more than 1 mm in the terminals		P
	Creepage distances and clearances not reduced below values specified in 29.1		P
25.16	Cord anchorages for type X attachments constructed and located so that:		N/A
	- replacement of the cord is easily possible		N/A
	- it is clear how the relief from strain and the prevention of twisting are obtained		N/A
	- they are suitable for different types of cord		N/A



IEC/EN 60335-1			
Clause	Requirement + Test	Result - Remark	Verdict
	- cord cannot touch the clamping screws of cord anchorage if these screws are accessible, unless separated from accessible metal parts by supplementary insulation		N/A
	- the cord is not clamped by a metal screw which bears directly on the cord		N/A
	- at least one part of the cord anchorage securely fixed to the appliance, unless part of a specially prepared cord		N/A
	- screws which have to be operated when replacing the cord do not fix any other component, if applicable		N/A
	- if labyrinths can be bypassed the test of 25.15 is nevertheless withstood		N/A
	- for Class 0, 0I and I appliances: they are of insulating material or are provided with an insulating lining, unless a failure of the insulation of the cord does not make accessible metal parts live		N/A
	- for Class II appliances: they are of insulating material, or if of metal, they are insulated from accessible metal parts by supplementary insulation		N/A
25.17	Adequate cord anchorages for type Y and Z attachment		P
25.18	Cord anchorages only accessible with the aid of a tool, or		N/A
	so constructed that the cord can only be fitted with the aid of a tool		P
25.19	Type X attachment, glands not used as cord anchorage in portable appliances		N/A
	Tying the cord into a knot or tying the cord with string not used		N/A
25.20	Conductors of the supply cord for type Y and Z attachment adequately additionally insulated		P
25.21	Space for supply cord for type X attachment or for connection of fixed wiring constructed to permit checking of conductors with respect to correct positioning and connection before fitting any cover, no risk of damage to the conductors when fitting the cover, no contact with accessible metal parts if a conductor becomes loose, etc.		N/A



IEC/EN 60335-1			
Clause	Requirement + Test	Result - Remark	Verdict
	For portable appliances, the uninsulated end of a conductor prevented from any contact with accessible metal parts, unless the end of the cord is such that the conductors are unlikely to slip free		P
25.22	Appliance inlet:		
	- live parts not accessible during insertion or removal		N/A
	- connector can be inserted without difficulty		N/A
	- the appliance is not supported by the connector		N/A
	- is not for cold conditions if temp. rise of external metal parts exceeds 75 K, unless the supply cord is not likely to touch such metal parts		N/A
25.23	Interconnection cords comply with the requirements for the supply cord, except as specified		N/A
	If necessary, electric strength test of 16.3		N/A
25.24	Interconnection cords not detachable without the aid of a tool if compliance with the standard is impaired when they are disconnected		N/A
25.25	Dimensions of pins compatible with the dimensions of the relevant socket-outlet. Dimensions of pins and engagement face in accordance with the relevant plug in IEC 60083		N/A
26	TERMINALS FOR EXTERNAL CONDUCTORS		—
26.1	Appliances provided with terminals or equally effective devices for connection of external conductors		P
	Terminals only accessible after removal of a non-detachable cover		P
	However, earthing terminals may be accessible if a tool is required to make the connections and means are provided to clamp the wire independently from its connection		N/A
26.2	Appliances with type X attachment and appliances for connection to fixed wiring provided with terminals in which connections are made by means of screws, nuts or similar devices, unless the connections are soldered		N/A
	Screws and nuts serve only to clamp supply conductors, except		N/A
	internal conductors, if so arranged that they are unlikely to be displaced when fitting the supply conductors		N/A

IEC/EN 60335-1			
Clause	Requirement + Test	Result - Remark	Verdict
	If soldered connections used, the conductor so positioned or fixed that reliance is not placed on soldering alone		N/A
	Soldering alone used, barriers provided, clearances and creepage distances satisfactory if the conductor becomes free at the soldered joint		N/A
26.3	Terminals for type X attachment and for connection to fixed wiring so constructed that the conductor is clamped between metal surfaces with sufficient contact pressure and without damaging the conductor		N/A
	Terminals for type X attachment and those for connection to fixed wiring so fixed that when tightening or loosening the clamping means:		N/A
	- the terminal does not loosen		N/A
	- internal wiring is not subjected to stress		N/A
	- clearances and creepage distances are not reduced below the values in 29		N/A
	Compliance checked by inspection and by the test of subclause 9.6 of IEC 60999-1, the torque applied being equal to two-thirds of the torque specified. Nominal diameter of thread (mm); screw category; torque (Nm):		N/A
26.4	Terminals for type X attachment, except those with a specially prepared cord, and those for connection to fixed wiring, no special preparation of conductors required, and so constructed or placed that conductors prevented from slipping out		N/A
26.5	Terminals for type X attachment so located or shielded that if a wire of a stranded conductor escapes, no risk of accidental connection to other parts that result in a hazard		N/A
	Stranded conductor test, 8 mm insulation removed		N/A
	No contact between live parts and accessible metal parts and, for class II constructions, between live parts and metal parts separated from accessible metal parts by supplementary insulation only		N/A
26.6	Terminals for type X attachment and for connection to fixed wiring suitable for connection of conductors with required cross-sectional area according to table 13; rated current (A); nominal cross-sectional area (mm ²).....:		N/A
	Terminals only suitable for a specially prepared cord		N/A



IEC/EN 60335-1			
Clause	Requirement + Test	Result - Remark	Verdict
26.7	Terminals for type X attachment accessible after removal of a cover or part of the enclosure		N/A
26.8	Terminals for the connection to fixed wiring, including the earthing terminal, located close to each other		N/A
26.9	Terminals of the pillar type constructed and located as specified		N/A
26.10	Terminals with screw clamping and screwless terminals not used for flat twin tinsel cords, unless conductors ends fitted with a device suitable for screw terminals		P
	Pull test of 5 N/A to the connection		N/A
26.11	For type Y and Z attachment: soldered, welded, crimped and similar connections may be used		P
	For Class II appliances: the conductor so positioned or fixed that reliance is not placed on soldering, welding or crimping alone		P
	For Class II appliances: soldering, welding or crimping alone used, barriers provided, clearances and creepage distances satisfactory if the conductor becomes free		N/A
27	PROVISION FOR EARTHING		—
27.1	Accessible metal parts of Class 0I and I appliances, permanently and reliably connected to an earthing terminal or contact of the appliance inlet		N/A
	Earthing terminals not connected to neutral terminal		N/A
	Class 0, II and III appliance have no provision for earthing		P
	Safety extra-low voltage circuits not earthed, unless protective extra-low voltage circuits		N/A
27.2	Clamping means adequately secured against accidental loosening		N/A
	Terminals used for the connection of external equipotential bonding conductors allow connection of conductors of 2.5 to 6 mm ² , and		N/A
	do not provide earthing continuity between different parts of the appliance		N/A
	Conductors cannot be loosened without the aid of a tool		N/A



IEC/EN 60335-1			
Clause	Requirement + Test	Result - Remark	Verdict
27.3	For detachable parts that are plugged into another part of the appliance, and having an earth connection, the earth connection made before and separated after current-carrying connections when removing the part		N/A
	For appliances with supply cord, current-carrying conductors become taut before earthing conductor, if the cord slips out of the cord anchorage		N/A
27.4	No risk of corrosion resulting from contact between metal of earthing terminal and other metal		N/A
	Adequate resistance to corrosion of coated or uncoated parts providing earthing continuity, other than parts of a metal frame or enclosure		N/A
	Parts of steel providing earthing continuity provided at the essential areas with an electroplated coating, thickness at least 5 µm		N/A
	Adequate protection against rusting of parts of coated or uncoated steel, only intended to provide or transmit contact pressure		N/A
	In case of aluminium alloys precautions taken to avoid risk of corrosion		N/A
27.5	Low resistance of connection between earthing terminal and earthed metal parts		N/A
	This requirement does not apply to connections providing earthing continuity in the protective extra-low voltage circuit, provided that clearances of basic insulation are based on the rated voltage of the appliance		N/A
	Resistance not exceeding 0,1 Ω at the specified low-resistance test		N/A
27.6	The printed conductors of printed circuit boards shall not be used to provide earthing continuity in hand-held appliances.		N/A
	They may be used to provide earthing continuity in other appliances if at least two tracks are used with independent soldering points and the appliance complies with 27.5 for each circuit		N/A
28	SCREWS AND CONNECTIONS		—
28.1	Fixings, electrical connections and connections providing earthing continuity withstand mechanical stresses		P



IEC/EN 60335-1			
Clause	Requirement + Test	Result - Remark	Verdict
	Screws not of soft metal liable to creep, such as zinc or aluminium		P
	Diameter of screws of insulating material min. 3 mm		N/A
	Screws of insulating material not used for any electrical connection or connections providing earthing continuity		P
	Screws used for electrical connections or connections providing earthing continuity screw into metal		N/A
	Screws not of insulating material if their replacement by a metal screw can impair supplementary or reinforced insulation		P
	Type X attachment, screws to be removed for replacement of supply cord or for user maintenance, not of insulating material if their replacement by a metal screw can impair basic insulation		N/A
	For screws and nuts; test as specified	(see appended table)	P
28.2	Electrical connections and connections providing earthing continuity constructed so that contact pressure not transmitted through insulating material liable to shrink or distort, unless shrinkage or distortion compensated		N/A
	This requirement does not apply to electrical connections in circuits carrying a current not exceeding 0.5A		N/A
28.3	Space-threaded (sheet metal) screws only used for electrical connections if they clamp the parts together		N/A
	Thread-cutting (self-tapping) screws and thread rolling screws only used for electrical connections if they generate a full form standard machine screw thread		N/A
	Thread-cutting (self-tapping) screws not used if they are likely to be operated by the user or installer		N/A
	Thread-cutting, thread rolling and space threaded screws may be used in connections providing earthing continuity provided it is not necessary to disturb the connection:		
	- in normal use,		N/A
	- during user maintenance,		N/A
	- when replacing a supply cord having a type X attachment, or		N/A
	- during installation		N/A



IEC/EN 60335-1			
Clause	Requirement + Test	Result - Remark	Verdict
	At least two screws being used for each connection providing earthing continuity, unless		N/A
	the screw forms a thread having a length of at least half the diameter of the screw		N/A
	Thread-cutting and space-threaded screws may be used in connections providing earthing continuity, provided unnecessary to disturb the connection and at least two screws are used for each connection		N/A
28.4	Screws and nuts that make mechanical connection secured against loosening if they also make electrical connections or connections providing earthing continuity		N/A
	Rivets for electrical connections or connections providing earthing continuity secured against loosening if subjected to torsion		N/A
29	CLEARANCES, CREEPAGE DISTANCES AND SOLID INSULATION		—
	Clearances, creepage distances and solid insulation withstand electrical stress		P
	For coatings used on printed circuits boards to protect the microenvironment (Type 1) or to provide basic insulation (Type 2), annex J applies		N/A
	The microenvironment is pollution degree 1 under Type 1 coating		N/A
	No clearance or creepage distance requirements under Type 2 coating		N/A
29.1	Clearances not less than the values specified in table 16, taking into account the rated impulse voltage for the overvoltage categories of table 15, unless		P
	for basic insulation and functional insulation they comply with the impulse voltage test of clause 14		N/A
	However, if the construction is affected by wear, distortion, movement of the parts or during assembly, the clearances for rated impulse voltages of 1500V and above are increased by 0,5 mm and the impulse voltage test is not applicable		N/A
	Impulse voltage test not applicable:		—
	- when the microenvironment is pollution degree 3		N/A
	- for basic insulation of class 0 and class 01 appliances		N/A
	Appliances are in overvoltage category II		P



IEC/EN 60335-1			
Clause	Requirement + Test	Result - Remark	Verdict
	Clearances less than specified in table 16 not allowed for basic insulation of class 0 and class 0I appliances,		N/A
	or if pollution degree 3 is applicable		N/A
	Compliance is checked by inspection and measurements as specified		P
29.1.1	Clearances of basic insulation withstand the overvoltages, taking into account the rated impulse voltage		N/A
	Clearance at the terminals of tubular sheathed heating elements may be reduced to 1mm if the microenvironment is pollution degree 1		N/A
	Lacquered conductors of windings considered to be bare conductors		N/A
29.1.2	Clearances of supplementary insulation not less than those specified for basic insulation in table 16		N/A
29.1.3	Clearances of reinforced insulation not less than those specified for basic insulation in table 16, but using the next higher step for rated impulse voltage		P
29.1.4	For functional insulation, the values of table 16 are applicable, unless		P
	the appliance complies with clause 19 with the functional insulation short-circuited		N/A
	Lacquered conductors of windings considered to be bare conductors		N/A
	However, clearances at crossover points are not measured		N/A
	Clearance between surfaces of PTC heating elements may be reduced to 1mm		N/A
29.1.5	Appliances having higher working voltage than rated voltage, the voltage used for determining clearances from table 16 is the sum of the rated impulse voltage and the difference between the peak value of the working voltage and the peak value of the rated voltage		N/A
	If the secondary winding of a step-down transformer is earthed, or if there is an earthed screen between the primary and secondary windings, clearances of basic insulation on the secondary side not less than those specified in table 16, but using the next lower step for rated impulse voltage		N/A

IEC/EN 60335-1			
Clause	Requirement + Test	Result - Remark	Verdict
	Circuits supplied with a voltage lower than rated voltage, clearances of functional insulation based on the working voltage used as the rated voltage in table 15		P
29.2	Creepage distances not less than those appropriate for the working voltage, taking into account the material group and the pollution degree		P
	Pollution degree 2 applies, unless		P
	precautions taken to protect the insulation; pollution degree 1		N/A
	insulation subjected to conductive pollution; pollution degree 3		N/A
	Compliance is checked by inspection and measurements as specified		P
29.2.1	Creepage distances of basic insulation not less than specified in table 17		N/A
	For pollution degree 1, creepage distance not less than the minimum specified for the clearance in table 16, if the clearance has been checked according to the test of clause 14		N/A
29.2.2	Creepage distances of supplementary insulation at least as specified for basic insulation in table 17		N/A
29.2.3	Creepage distances of reinforced insulation at least double as specified for basic insulation in table 17		P
29.2.4	Creepage distances of functional insulation not less than specified in table 18		P
	Creepage distances may be reduced if the appliance complies with clause 19 with the functional insulation short-circuited		N/A
29.3	Supplementary and reinforced insulation having adequate thickness, or a sufficient number of layers, to withstand the electrical stresses		P
	Compliance checked by:		
	- measurement, in accordance with 29.3.1, or		N/A
	- an electric strength test in accordance with 29.3.2, or		P
	- an assessment of the thermal quality of the material combined with an electric strength test, in accordance with 29.3.3		N/A
29.3.1	Supplementary insulation having a thickness of at least 1 mm		N/A



IEC/EN 60335-1			
Clause	Requirement + Test	Result - Remark	Verdict
	Reinforced insulation having a thickness of at least 2 mm		N/A
29.3.2	Each layer of material withstand the electric strength test of 16.3 for supplementary insulation		N/A
	Supplementary insulation consisting of at least 2 layers		N/A
	Reinforced insulation consisting of at least 3 layers		P
29.3.3	The insulation is subjected to the dry heat test Bb of IEC 60068-2-2, followed by		N/A
	the electric strength test of 16.3		N/A
	If the temperature rise during the tests of Clause 19 does not exceed the value specified in Table 3, the test of IEC 60068-2-2 is not carried out		N/A
30	RESISTANCE TO HEAT AND FIRE		—
30.1	External parts of non-metallic material,		P
	parts supporting live parts, and		P
	thermoplastic material providing supplementary or reinforced insulation,		N/A
	sufficiently resistant to heat		P
	Ball-pressure test according to IEC 60695-10-2		P
	External parts: at 40 °C plus the maximum temperature rise determined during the test of clause 11, or at 75 °C, whichever is the higher; temperature (°C)	75 °C	P
	Parts supporting live parts: at 40°C plus the maximum temperature rise determined during the test of clause 11, or at 125°C, whichever is the higher; temperature (°C)	125 °C	P
	Parts of thermoplastic material providing supplementary or reinforced insulation, 25°C plus the maximum temperature rise determined during clause 19, if higher; temperature (°C)		N/A
30.2	Parts of non-metallic material adequately resistant to ignition and spread of fire		P
	This requirement does not apply to decorative trims, knobs and other parts unlikely to be ignited or to propagate flames that originate inside the appliance		P
	Compliance checked by the test of 30.2.1. In addition:		P

IEC/EN 60335-1			
Clause	Requirement + Test	Result - Remark	Verdict
	- attended appliances, 30.2.2 applies		P
	- unattended appliances, 30.2.3 applies		N/A
	Appliances for remote operation, 30.2.3 applies		N/A
	Base material of printed circuit board, 30.2.4 applies		N/A
30.2.1	Glow-wire test of IEC 60695-2-11 at 550 °C, unless		P
	the material is classified at least HB40 according to IEC 60695-11-10		N/A
	Parts for which the glow-wire test cannot be carried out meet the requirements in ISO9772 for category HBF material		N/A
30.2.2	Appliances operated while attended, parts of non-metallic material supporting current-carrying connections, and parts of non-metallic material within a distance of 3mm of such connections, are subjected to the glow-wire test of IEC 60695-2-11.		P
	The glow-wire test is not carried out on parts of material classified as having a glow-wire flammability index according to IEC 60695-2-12 of at least:		
	-750°C, for connections carrying a current exceeding 0,5A during normal operation		N/A
	-650°C, for other connections		N/A
	Test as specified for an interposed shielding material		N/A
	When the glow-wire test of IEC 60695-2-11 is carried out, the temperatures are:		
	-750°C, for connections carrying a current exceeding 0,5A during normal operation		P
	-650°C, for other connections		P
	Test not applicable to conditions as specified		N/A
30.2.3	Appliances operated while unattended, tested as specified in 30.2.3.1 and 30.2.3.2		N/A
	Tests not applicable to conditions as specified		N/A
30.2.3.1	Parts of insulating material supporting connections carrying a current exceeding 0.2A during normal operation, and		N/A
	parts of non-metallic material within a distance of 3mm,		N/A
	subjected to the glow-wire test of IEC 60695-2-11 with a test severity of 850°C		N/A



IEC/EN 60335-1			
Clause	Requirement + Test	Result - Remark	Verdict
	Glow-wire test not carried out on parts of material classified as having a glow-wire flammability index of at least 850°C according to IEC 60695-2-12		N/A
	Glow-wire test not carried out on small parts that comply with the needle-flame test of Annex E or on small parts of material classified as V-0 or V-1 according to IEC 60695-11-10		N/A
	Test as specified for an interposed shielding material		N/A
30.2.3.2	Parts of non-metallic material supporting current-carrying connections, and		N/A
	parts of non-metallic material within a distance of 3mm,		N/A
	subjected to glow-wire test of IEC 60695-2-11		N/A
	Test not carried out on material having a glow-wire ignition temperature according to IEC 60695-2-13 of at least:		N/A
	-775°C, for connections carrying a current exceeding 0,2A during normal operation		N/A
	-675°C, for other connections		N/A
	When the glow-wire test of IEC 60695-2-11 is carried out, the temperatures are:		
	-750°C, for connections carrying a current exceeding 0,2A during normal operation		N/A
	-650°C, for other connections		N/A
	Parts that during the test produce a flame persisting longer than 2 s, tested as specified		N/A
	If a flame persists longer than 2 s during the test, parts above the connection, as specified, subjected to the needle-flame test of annex E, unless		N/A
	the material is classified as V-0 or V-1 according to IEC 60695-11-10		N/A
30.2.4	Base material of printed circuit boards subjected to needle-flame test of annex E		N/A
	Test not applicable to conditions as specified		N/A
31	RESISTANCE TO RUSTING		—
	Relevant ferrous parts adequately protected against rusting		P
32	RADIATION, TOXICITY AND SIMILAR HAZARDS		—



IEC/EN 60335-1			
Clause	Requirement + Test	Result - Remark	Verdict
	Appliance shall not emit harmful radiation, present a toxic or similar hazard due to their operation in normal use		P
	Relevant tests specified in part 2, if necessary		P
A	ANNEX A (INFORMATIVE) ROUTINE TESTS		
	Description of routine tests to be carried out by the manufacturer		P
B	ANNEX B (NORMATIVE) APPLIANCES POWERED BY RECHARGEABLE BATTERIES		
	The following modifications to this standard are applicable for appliances powered by batteries that are recharged in the appliance		N/A
	This annex does not apply to battery chargers		N/A
3.1.9	Appliance operated under the following conditions:		
	-the appliance, supplied by its fully charged battery, operated as specified in relevant part 2		N/A
	-the battery is charged, the battery being initially discharged to such an extent that the appliance cannot operate		N/A
	-if possible, the appliance is supplied from the supply mains through its battery charger, the battery being initially discharged to such an extent that the appliance cannot operate. The appliance is operated as specified in relevant part 2		N/A
	If the appliance incorporates inductive coupling between two parts that are detachable from each other, the appliance is supplied from the supply mains with the detachable part removed		N/A
3.6.2	Part to be removed in order to discard the battery is not considered to be detachable		N/A
5.101	Appliances supplied from the supply mains tested as specified for motor-operated appliances		N/A
7.1	Battery compartment for batteries intended to be replaced by the user, marked with battery voltage and polarity of the terminals		N/A
7.12	The instructions for appliances incorporating batteries intended to be replaced by the user includes required information		N/A
	Details about how to remove batteries containing materials hazardous to the environment given		N/A



IEC/EN 60335-1			
Clause	Requirement + Test	Result - Remark	Verdict
7.15	Markings placed on the part of the appliance connected to the supply mains		N/A
8.2	Appliances having batteries that according to the instruction may be replaced by the user need only have basic insulation between live parts and the inner surface of the battery compartment		N/A
	If the appliance can be operated without batteries, double or reinforced insulation required		N/A
11.7	The battery is charged for the period described		N/A
19.1	Appliances subjected to tests of 19.101, 19.102 and 19.103		N/A
19.101	Appliances supplied at rated voltage for 168 h, the battery being continually charged		N/A
19.102	Short-circuiting of the terminals of the battery, being fully charged, for appliances having batteries that can be removed without the aid of a tool		N/A
19.103	Appliances having batteries replaceable by the user supplied at rated voltage under normal operation with the battery removed or in any position allowed by the construction		N/A
21.101	Appliances having pins for insertion into socket-outlets have adequate mechanical strength, checked according to procedure 2 of IEC 68-2-32		N/A
	Part of the appliance incorporating the pins subjected to the free fall test, procedure 2, of IEC 60068-2-32, the number of falls being:		
	- 100, the mass of part does not exceed 250 g		N/A
	- 50, the mass of part exceeds 250 g		N/A
	After the test, the requirements of 8.1, 15.1.1, 16.3 and clause 29 are met		N/A
22.3	Appliances having pins for insertion into socket-outlets tested as fully assembled as possible		N/A
25.13	An additional lining or bushing not required for interconnection cords operating at safety extra-low voltage		N/A
30.2	For parts of the appliance connected to the supply mains during the charging period, 30.2.3 applies		N/A
	For other parts, 30.2.2 applies		N/A
C	ANNEX C (NORMATIVE) AGEING TEST ON MOTORS		—

IEC/EN 60335-1			
Clause	Requirement + Test	Result - Remark	Verdict
	Tests, as described, carried out when doubt with regard to the temperature classification of the insulation of a motor winding		N/A
D	ANNEX D (NORMATIVE) THERMAL MOTOR PROTECTORS		—
	Applicable to appliances having motors that incorporate thermal motor protectors		N/A
E	ANNEX E (NORMATIVE) NEEDLE-FLAME TEST		—
	Needle-flame test carried out in accordance with IEC 60695-11-5, with the following modifications:		N/A
7	Severities		
	The duration of application of the test flame is 30 s ± 1 s		N/A
9	Test procedure		N/A
9.1	The specimen so arranged that the flame can be applied to a vertical or horizontal edge as shown in the examples of figure 1		N/A
9.2	The first paragraph does not apply		N/A
	If possible, the flame is applied at least 10 mm from a corner		N/A
9.3	The test is carried out on one specimen		N/A
	If the specimen does not withstand the test, the test may be repeated on two additional specimens, both withstanding the test		N/A
11	Evaluation of test results		
	The duration of burning not exceeding 30 s		N/A
	However, for printed circuit boards, the duration of burning not exceeding 15 s		N/A
F	ANNEX F (NORMATIVE) CAPACITORS		
	Capacitors likely to be permanently subjected to the supply voltage, and used for radio interference suppression or voltage dividing, comply with the following clauses of IEC 60384-14, with the following modifications:		N/A
1.5	Terminology		
1.5.3	Class X capacitors tested according to subclass X2		N/A
1.5.4	This subclause is applicable		N/A



IEC/EN 60335-1			
Clause	Requirement + Test	Result - Remark	Verdict
1.6	Marking		
	Items a) and b) are applicable		N/A
3.4	Approval testing		
3.4.3.2	Table II is applicable as described		N/A
4.1	Visual examination and check of dimensions		
	This subclause is applicable		N/A
4.2	Electrical tests		
4.2.1	This subclause is applicable		N/A
4.2.5	This subclause is applicable		N/A
4.2.5.2	Only table IX is applicable		N/A
	Values for test A apply		N/A
	However, for capacitors in heating appliances the values for test B or C apply		N/A
4.12	Damp heat, steady state		
	This subclause is applicable		N/A
	Only insulation resistance and voltage proof are checked		N/A
4.13	Impulse voltage		
	This subclause is applicable		N/A
4.14	Endurance		
	Subclauses 4.14.1, 4.14.3, 4.14.4 and 4.14.7 applicable		N/A
4.14.7	Only insulation resistance and voltage proof are checked		
	Visual examination, no visible damage		N/A
4.17	Passive flammability test		
	This subclause is applicable		N/A
4.18	Active flammability test		
	This subclause is applicable		N/A
G	ANNEX G (NORMATIVE) SAFETY ISOLATING TRANSFORMERS		
	The following modifications to this standard are applicable for safety isolating transformers:		N/A
7	Marking and instructions		



IEC/EN 60335-1			
Clause	Requirement + Test	Result - Remark	Verdict
7.1	Transformers for specific use marked with:		
	-name, trademark or identification mark of the manufacturer or responsible vendor		N/A
	-model or type reference		N/A
17	Overload protection of transformers and associated circuits		
	Fail-safe transformers comply with subclause 15.5 of IEC 61558-1		N/A
22	Construction		
	Subclauses 19.1 and 19.1.2 of IEC 61558-2-6 are applicable		N/A
29	Clearances, creepage distances and solid insulation		
29.1, 29.2 and 29.3	The distances specified in items 2a, 2c and 3 in table 13 of IEC 61558-1 apply		N/A
H	ANNEX H (NORMATIVE) SWITCHES		
	Switches comply with the following clauses of IEC 61058-1, as modified:		
	-The tests of IEC 61058-1 carried out under the conditions occurring in the appliance		N/A
	-Before being tested, switches are operated 20 times without load		N/A
8	Marking and documentation		
	Switches are not required to be marked		N/A
	However, switches that can be tested separately from the appliance marked with the manufacturer's name or trade mark and the type reference		N/A
13	Mechanism		
	The tests may be carried out on a separate sample		N/A
15	Insulation resistance and dielectric strength		
15.1	Not applicable		N/A
15.2	Not applicable		N/A
15.3	Applicable for full disconnection and micro-disconnection		N/A
17	Endurance		
	Compliance is checked on three separate appliances or switches		N/A



IEC/EN 60335-1			
Clause	Requirement + Test	Result - Remark	Verdict
	For 17.2.4.4, the number of cycles is 10 000, unless otherwise specified in 24.1.3 of the relevant part 2 of IEC 60335		N/A
	Switches for operation under no load and which can be operated only by a tool and switches operated by hand that are interlocked so that they cannot be operated under load, are not subjected to the tests		N/A
	Subclauses 17.2.2 and 17.2.5.2 not applicable		N/A
	The ambient temperature during the test is that occurring in the appliance during the test of Clause 11 in IEC 60335-1		N/A
	Temperature rise of the terminals not more than 30 K above the temperature rise measured in clause 11 of IEC 60335-1		N/A
20	Clearances, creepage distances, solid insulation and coatings of rigid printed board assemblies		
	This clause is applicable to clearances and creepage distances for functional insulation, across full disconnection and micro-disconnection, as stated in table 24		N/A
I	ANNEX I (NORMATIVE) MOTORS HAVING BASIC INSULATION THAT IS INADEQUATE FOR THE RATED VOLTAGE OF THE APPLIANCE		
	The following modifications to this standard are applicable for motors having basic insulation that is inadequate for the rated voltage of the appliance:		N/A
8	Protection against access to live parts		
8.1	Metal parts of the motor are considered to be bare live parts		N/A
11	Heating		
11.3	Temperature rise of the body of the motor is determined instead of the temperature rise of the windings		N/A
11.8	Temperature rise of the body of the motor, where in contact with insulating material, not exceeding values in table 3 for the relevant insulating material		N/A
16	Leakage current and electric strength		
16.3	Insulation between live parts of the motor and its other metal parts not subjected to the test		N/A
19	Abnormal operation		
19.1	The tests of 19.7 to 19.9 not carried out		N/A



IEC/EN 60335-1			
Clause	Requirement + Test	Result - Remark	Verdict
19.101	Appliance operated at rated voltage with each of the following fault conditions:		
	- short circuit of the terminals of the motor, including any capacitor incorporated in the motor circuit		N/A
	- short circuit of each diode of the rectifier		N/A
	- open circuit of the supply to the motor		N/A
	- open circuit of any parallel resistor, the motor being in operation		N/A
	Only one fault simulated at a time, the tests carried out consecutively		N/A
22	Construction		
22.101	For class I appliances incorporating a motor supplied by a rectifier circuit, the d.c. circuit being insulated from accessible parts of the appliance by double or reinforced insulation		N/A
	Compliance checked by the tests specified for double and reinforced insulation		N/A
J	ANNEX J (NORMATIVE) COATED PRINTED CIRCUIT BOARDS		
	Testing of protective coatings of printed circuit boards carried out in accordance with IEC 60664-3 with the following modifications:		N/A
5.7	Conditioning of the test specimens		
	When production samples are used, three samples of the printed circuit board are tested		N/A
5.7.1	Cold		
	The test is carried out at -25°C		N/A
5.7.3	Rapid change of temperature		
	Severity 1 is specified		N/A
5.9	Additional tests		
	This subclause is not applicable		N/A
K	ANNEX K (NORMATIVE) OVERVOLTAGE CATEGORIES		
	The information on overvoltage categories is extracted from IEC 60664-1		P
	Overvoltage category is a numeral defining a transient overvoltage condition		P
	Equipment of overvoltage category IV is for use at the origin of the installation		N/A

IEC/EN 60335-1			
Clause	Requirement + Test	Result - Remark	Verdict
	Equipment of overvoltage category III is equipment in fixed installations and for cases where the reliability and the availability of the equipment is subject to special requirements		N/A
	Equipment of overvoltage category II is energy consuming equipment to be supplied from the fixed installation		P
	If such equipment is subjected to special requirements with regard to reliability and availability, overvoltage category III applies		N/A
	Equipment of overvoltage category I is equipment for connection to circuits in which measures are taken to limit transient overvoltages to an appropriate low level		N/A
L	ANNEX L (INFORMATIVE) GUIDANCE FOR THE MEASUREMENT OF CLEARANCES AND CREEPAGE DISTANCES		
	Sequences for the determination of clearances and creepage distances		P
M	ANNEX M (NORMATIVE) POLLUTION DEGREE		
	The information on pollution degrees is extracted from IEC 60664-1		P
	Pollution		
	The microenvironment determines the effect of pollution on the insulation, taking into account the microenvironment		P
	Means may be provided to reduce pollution at the insulation by effective enclosures or similar		P
	Minimum clearances specified where pollution may be present in the microenvironment		P
	Degrees of pollution in the microenvironment		
	For evaluating creepage distances, the following degrees of pollution in the microenvironment are established:		
	- pollution degree 1: no pollution or only dry, non-conductive pollution occurs. The pollution has no influence		N/A
	- pollution degree 2: only non-conductive pollution occurs, except that occasionally a temporary conductivity caused by condensation is to be expected		P



IEC/EN 60335-1			
Clause	Requirement + Test	Result - Remark	Verdict
	- pollution degree 3: conductive pollution occurs or dry non-conductive pollution occurs that becomes conductive due to condensation that is to be expected		N/A
	- pollution degree 4: the pollution generates persistent conductivity caused by conductive dust or by rain or snow		N/A
N	ANNEX N (NORMATIVE) PROOF TRACKING TEST		
	The proof tracking test is carried out in accordance with IEC 60112 with the following modifications:		N/A
7	Test apparatus		
7.3	Test solutions		
	Test solution A is used		N/A
10	Determination of proof tracking index (PTI)		
10.1	Procedure		
	The proof voltage is 100V, 175V, 400V or 600V		N/A
	The last paragraph of Clause 3 applies		N/A
	The test is carried out on five specimens		N/A
	In case of doubt, additional test with proof voltage reduced by 25V, the number of drops increased to 100		N/A
10.2	Report		
	The report stating if the PTI value was based on a test using 100 drops with a test voltage of (PTI-25) V		N/A
O	ANNEX O (INFORMATIVE) SELECTION AND SEQUENCE OF THE TESTS OF CLAUSE 30		
	Description of tests for determination of resistance to heat and fire		P
P	ANNEX P (INFORMATIVE) GUIDANCE FOR THE APPLICATION OF THIS STANDARD TO APPLIANCES USED IN WARM DAMP EQUABLE CLIMATES		
	Modifications applicable for class 0 and 01 appliances having a rated voltage exceeding 150V, intended to be used in countries having a warm damp equable climate and that are marked WDaE		
	Modifications may also be applied to class 1 appliances having a rated voltage exceeding 150V, intended to be used in countries having a warm damp equable climate and that are marked WdaE, if liable to be connected to a supply mains that excludes the protective earthing conductor		



IEC/EN 60335-1			
Clause	Requirement + Test	Result - Remark	Verdict
5	General conditions for the tests		
5.7	The ambient temperature for the tests of Clauses 11 and 13 is 40 ⁺³ / ₀		N/A
7	Marking and instructions		
7.1	The appliance marked with the letters WDaE		N/A
7.12	The instructions state that the appliance is to be supplied through a RCD having a rated residual operating current not exceeding 30 mA		N/A
	The instructions state that the appliance is considered to be suitable for use in countries having a warm damp equable climate, but may also be used in other countries		N/A
11	Heating		
11.8	The values of Table 3 are reduced by 15 K		N/A
13	Leakage current and electric strength at operating temperature		
13.2	The leakage current for class I appliances not exceeding 0,5 mA		N/A
15	Moisture resistance		
15.3	The value of t is 37 °C		N/A
16	Leakage current and electric strength		
16.2	The leakage current for class I appliances not exceeding 0,5 mA		N/A
19	Abnormal operation		
19.13	The leakage current test of 16.2 is applied in addition to the electric strength test of 16.3		N/A
Q	ANNEX Q (INFORMATIVE) SEQUENCE OF TESTS FOR THE EVALUATION OF ELECTRONIC CIRCUITS		
	Description of tests for appliances incorporating electronic circuits		N/A
R	ANNEX R (NORMATIVE) SOFTWARE EVALUATION		
	Software evaluated in accordance with the following clauses of Annex H of IEC 60730-1, as modified		N/A
H.2	Definitions		
	Only definitions H.2.16 to H.2.20 applicable		N/A
H.7	Information		
	Only footnotes 12) to 18) of Table 7.2, as modified, applicable		N/A



IEC/EN 60335-1			
Clause	Requirement + Test	Result - Remark	Verdict
H.11.12	Controls using software		
	All the subclauses of H.11.12, as modified, except H.11.12.6 and H.11.12.6.1, applicable		N/A
H.11.12.7	Delete text		N/A
H.11.12.7.1	For appliances using software class C having a single channel with self-test and monitoring structure, the manufacturer provides the measures necessary to address the fault/errors in safety related segments and data		N/A
H.11.12.8	Software fault/error detection occurs before compliance with 19.13 of IEC 60335-1 is impaired		N/A
H.11.12.8.1	Replace text		N/A
H.11.12.13	Software and safety related hardware under its control initializes and terminates before compliance with 19.13 of IEC 60335-1 is impaired		N/A
ANNEX EMF			
	The Tested product also complies to the requirements of EN 62233:2008		
	Limit100%	Measured max.: 48.8 %	P

10.1	TABLE: Power input deviation					N/A
Input deviation of/at:	P rated (W)	P measured (W)	dP	Required dP	Remark	

10.2	TABLE: Current deviation					N/A
Current deviation of/at:	I rated (A)	I measured (A)	dI	Required dI	Remark	
230 V, 50 Hz	1.02	1.0	+2.0%	-		

11.8	TABLE: Heating test, thermocouples			P
	Test voltage (V)	216.2		—
	Ambient (°C)	17.5		—
Thermocouple locations		dT (K)	Max. dT (K)	
Electrolysis device enclosure		1.7	-	
Electrolysis device input wire		9.3	50	
Internal wire		2.5	50	
SMPS Transformer core		45.8	65	
SMPS Transformer coil		33.5	65	
X Capacitor C13		39.5	75	
Electrolytic capacitor C12		35.3	60	
Power switch		1.2	60	
Enclosure		4.1	60	
Power cord		0	50	

11.8	TABLE: Heating test, thermocouples			P
	Test voltage (V)	243.8		—
	Ambient (°C)	17.5		—
	Thermocouple locations	dT (K)	Max. dT (K)	
	Electrolysis device enclosure	2.6	-	
	Electrolysis device input wire	9.9	50	
	Internal wire	2.9	50	
	SMPS Transformer core	46.5	65	
	SMPS Transformer coil	34.6	65	
	X Capacitor C13	40.9	75	
	Electrolytic capacitor C12	36.0	60	
	Power switch	1.4	60	
	Enclosure	4.5	60	
	Power cord	0	50	

11.8	TABLE: Heating test, resistance method					N/A
	Test voltage (V)					—
	Ambient, t ₁ (°C)					—
	Ambient, t ₂ (°C)					—
	Temperature rise of winding	R ₁ (Ω)	R ₂ (Ω)	dT (K)	Max. dT (K)	Insulation class

13.2	TABLE: Leakage current			P
	Heating appliances: 1.15 x rated input			—
	Motor-operated and combined appliances: 1.06 x rated voltage	243.8 V		—
	Leakage current between	I (mA)	Max. allowed I (mA)	
	Live and Accessible part	0.07	0.25	
	Neutral and Accessible part	0.07	0.25	



13.3	TABLE: Electric strength		P
Test voltage applied between:		Voltage (V)	Breakdown (Yes/No)
Live parts and accessible parts		3000	No

14	TABLE: Transient overvoltages				N/A
Clearance between:	CI (mm)	Required CI (mm)	Rated impulse voltage (V)	Impulse test voltage (V)	Flashover (Yes/No)

16.2	TABLE: Leakage current		P
	Single phase appliances: 1.06 x rated voltage	243.8 V	—
	Three phase appliances 1.06 x rated voltage divided by $\sqrt{3}$:		—
Leakage current between		I (mA)	Max. allowed I (mA)
Live and Accessible part		0.07	0.25
Neutral and Accessible part		0.07	0.25

16.3	TABLE: Electric strength		P
Test voltage applied between:		Voltage (V)	Breakdown (Yes/No)
Live parts and accessible parts		3000	No

17	TABLE: Overload protection, temperature rise		N/A
Temperature rise of part/at:		dT (K)	Max. dT (K)

19.7	TABLE: Abnormal operation, locked rotor/moving parts					N/A
	Test voltage (V)					—
	Ambient, t_1 (°C)					—
	Ambient, t_2 (°C)					—
	Temperature of winding	R_1 (Ω)	R_2 (Ω)	dT (K)	T (°C)	Max. T (°C)

19.9	TABLE: Abnormal operation, running overload					N/A
	Test voltage (V)					—
	Ambient, t_1 (°C)					—
	Ambient, t_2 (°C)					—
	Temperature of winding	R_1 (Ω)	R_2 (Ω)	dT (K)	T (°C)	Max. T (°C)

19.13	TABLE: Abnormal operation, temperature rises		P
	Thermocouple locations	dT (K)	Max. dT (K)
	Power cord	0	150



24.1		TABLE: Components				P
Object / part No.	Manufacturer/ trademark	Type / model	Technical data	Standard	Mark(s) of conformity	
Power plug	Korea KDK	KKP-419C	250 V~, 2.5 A	EN 60884-1	VDE	
Power cord	Korea KDK	H03VVH2-F	2 X 0.75 mm ²	EN 60227	VDE	
Power switch	Light Country Co. Ltd.	R19	250 V~, 6 A	EN 61058-1	VDE	
Fuse	Suzhou Littelfuse OVS Ltd.	218.002	250 V~, 2 A	EN 60127-1 EN 60127-2	VDE	
Fuse holder	Littelfuse Inc.	3453XX	250 V~, 10 A	EN 60127-1 EN 60127-2	VDE	
Enclosure	LG Chemical Ltd.	HF 380	HB	EN 60335-1	Tested in appliance	
SMPS	Taesan Electronic.co.ltd	IONIA POWER Rev1.2	Input:110-240 V~, 50 Hz Output: dc 5 V,24 V, 30 V	EN 60335-1	Tested in appliance	
Fuse (F1) (in SMPS)	Suzhou Littelfuse OVS Ltd.	217 series	250 V~, 8 A	EN 60127-1 EN 60127-2	VDE	
X-Capacitor (C13, C14) (in SMPS)	PILKOR	PCX2 337	275 V~, 0.68 μ F	EN 60384-14	ENEC	
Varistor (Z1) (in SMPS)	AMOTECH CO., Ltd.	INR14D 561	560 V	EN 61051-1 EN 61051-2 EN 61051-2-2	VDE	
Transformer (T1) (in SMPS)	AUTORO Co., Ltd.	KM3007	1 mH \pm 20%	EN 60335-1	Tested in appliance	
Transformer (T2) (in SMPS)	TAE RIM Electronics Co.	HP45	4.1 mH \pm 10%	EN 60335-1	Tested in appliance	
Optocoupler (PC1, PC2) (in SMPS)	SHARP	PC817	35 V, 50 mA	EN 60825-1	VDE	

¹⁾ An asterisk indicates a mark which assures the agreed level of surveillance



28.1	TABLE: Threaded part torque test			P
Threaded part identification	Diameter of thread (mm)	Column number (I, II, or III)	Applied torque (Nm)	
Screw	3.89	II	1.2	

29.1	TABLE: Clearances					P
	Overvoltage category.....:	II				—
		Type of insulation:				
Rated impulse voltage (V):	Min. cl (mm)	Basic	Functional	Supplementary	Reinforced	Verdict / Remark
330	0,5*	-	-	-	-	N/A
500	0,5*	-	-	-	-	N/A
800	0,5*	-	-	-	-	N/A
1500	0,5*/**	-	-	-	-	N/A
2500	1,5**	-	-	-	-	N/A
4000	3,0**	-	-	-	3.5	P
6000	5,5**	-	-	-	-	N/A
8000	8,0**	-	-	-	-	N/A
10000	11,0**	-	-	-	-	N/A
*) The value is increased to 0,8mm for pollution degree 3 *) If the construction is affected by wear, distortion, movement of the parts or during assembly, the value is increased by 0,5 mm						



29.2	TABLE: Creepage distances, basic, supplementary and reinforced insulation										P	
Working voltage (V)	Creepage distance (mm) Pollution degree							Type of insulation				Verdict
	1	2			3							
	Material group				Material group							
	I	II	IIIa/IIIb	I	II	IIIa/IIIb	B ^{*)}	S ^{*)}	R ^{*)}			
≤50	0,2	0,6	0,9	1,2	1,5	1,7	1,9		—	—	N/A	
≤50	0,2	0,6	0,9	1,2	1,5	1,7	1,9	—		—	N/A	
≤50	0,4	1,2	1,8	2,4	3,0	3,4	3,8	—	—		N/A	
>50 and ≤125	0,3	0,8	1,1	1,5	1,9	2,1	2,4		—	—	N/A	
>50 and ≤125	0,3	0,8	1,1	1,5	1,9	2,1	2,4	—		—	N/A	
>50 and ≤125	0,6	1,6	2,2	3,0	3,8	4,2	4,8	—	—		N/A	
>125 and ≤250	0,6	1,3	1,8	2,5	3,2	3,6	4,0	—	—	—	N/A	
>125 and ≤250	0,6	1,3	1,8	2,5	3,2	3,6	4,0	—	—	—	N/A	
>125 and ≤250	1,2	2,6	3,6	5.0	6,4	7,2	8,0	—	—	5.0	P	
>250 and ≤400	1,0	2,0	2,8	4,0	5,0	5,6	6,3		—	—	N/A	
>250 and ≤400	1,0	2,0	2,8	4,0	5,0	5,6	6,3	—	—	—	N/A	
>250 and ≤400	2,0	4,0	5,6	8,0	10,0	11,2	12,6	—	—	—	N/A	
>400 and ≤500	1,3	2,5	3,6	5,0	6,3	7,1	8,0		—	—	N/A	
>400 and ≤500	1,3	2,5	3,6	5,0	6,3	7,1	8,0	—		—	N/A	
>400 and ≤500	2,6	5,0	7,2	10,0	12,6	14,2	16,0	—	—		N/A	
>500 and ≤800	1,8	3,2	4,5	6,3	8,0	9,0	10,0		—	—	N/A	
>500 and ≤800	1,8	3,2	4,5	6,3	8,0	9,0	10,0	—		—	N/A	
>500 and ≤800	3,6	6,4	9,0	12,6	16,0	18,0	20,0	—	—		N/A	
>800 and ≤1000	2,4	4,0	5,6	8,0	10,0	11,0	12,5		—	—	N/A	
>800 and ≤1000	2,4	4,0	5,6	8,0	10,0	11,0	12,5	—		—	N/A	
>800 and ≤1000	4,8	8,0	11,2	16,0	20,0	22,0	25,0	—	—		N/A	
>1000 and ≤1250	3,2	5,0	7,1	10,0	12,5	14,0	16,0		—	—	N/A	
>1000 and ≤1250	3,2	5,0	7,1	10,0	12,5	14,0	16,0	—		—	N/A	
>1000 and ≤1250	6,4	10,0	14,2	20,0	25,0	28,0	32,0	—	—		N/A	
>1250 and ≤1600	4,2	6,3	9,0	12,5	16,0	18,0	20,0		—	—	N/A	
>1250 and ≤1600	4,2	6,3	9,0	12,5	16,0	18,0	20,0	—		—	N/A	
>1250 and ≤1600	8,4	12,6	18,0	25,0	32,0	36,0	40,0	—	—		N/A	
>1600 and ≤2000	5,6	8,0	11,0	16,0	20,0	22,0	25,0		—	—	N/A	
>1600 and ≤2000	5,6	8,0	11,0	16,0	20,0	22,0	25,0	—		—	N/A	



>1600 and ≤2000	11,2	16,0	22,0	32,0	40,0	44,0	50,0	—	—		N/A
>2000 and ≤2500	7,5	10,0	14,0	20,0	25,0	28,0	32,0		—	—	N/A
>2000 and ≤2500	7,5	10,0	14,0	20,0	25,0	28,0	32,0	—		—	N/A
>2000 and ≤2500	15,0	20,0	28,0	40,0	50,0	56,0	64,0	—	—		N/A
>2500 and ≤3200	10,0	12,5	18,0	25,0	32,0	36,0	40,0		—	—	N/A
>2500 and ≤3200	10,0	12,5	18,0	25,0	32,0	36,0	40,0	—		—	N/A
>2500 and ≤3200	20,0	25,0	36,0	50,0	64,0	72,0	80,0	—	—		N/A
>3200 and ≤4000	12,5	16,0	22,0	32,0	40,0	45,0	50,0		—	—	N/A
>3200 and ≤4000	12,5	16,0	22,0	32,0	40,0	45,0	50,0	—		—	N/A
>3200 and ≤4000	25,0	32,0	44,0	64,0	80,0	90,0	100,0	—	—		N/A
>4000 and ≤5000	16,0	20,0	28,0	40,0	50,0	56,0	63,0		—	—	N/A
>4000 and ≤5000	16,0	20,0	28,0	40,0	50,0	56,0	63,0	—		—	N/A
>4000 and ≤5000	32,0	40,0	56,0	80,0	100,0	112,0	126,0	—	—		N/A
>5000 and ≤6300	20,0	25,0	36,0	50,0	63,0	71,0	80,0		—	—	N/A
>5000 and ≤6300	20,0	25,0	36,0	50,0	63,0	71,0	80,0	—		—	N/A
>5000 and ≤6300	40,0	50,0	72,0	100,0	126,0	142,0	160,0	—	—		N/A
>6300 and ≤8000	25,0	32,0	45,0	63,0	80,0	90,0	100,0		—	—	N/A
>6300 and ≤8000	25,0	32,0	45,0	63,0	80,0	90,0	100,0	—		—	N/A
>6300 and ≤8000	50,0	64,0	90,0	126,0	160,0	180,0	200,0	—	—		N/A
>8000 and ≤10000	32,0	40,0	56,0	80,0	100,0	110,0	125,0		—	—	N/A
>8000 and ≤10000	32,0	40,0	56,0	80,0	100,0	110,0	125,0	—		—	N/A
>8000 and ≤10000	64,0	80,0	112,0	160,0	200,0	220,0	250,0	—	—		N/A
>10000 and ≤12500	40,0	50,0	71,0	100,0	125,0	140,0	160,0		—	—	N/A
>10000 and ≤12500	40,0	50,0	71,0	100,0	125,0	140,0	160,0	—		—	N/A
>10000 and ≤12500	80,0	100,0	142,0	200,0	250,0	280,0	320,0	—	—		N/A

*) , B=Basic, S=Supplementary and R=Reinforced

29.2	TABLE: Creepage distances, functional insulation								P
Working voltage (V)	Creepage distance (mm)							Verdict / Remark	
	Pollution degree								
	1	2			3				
		Material group			Material group				
		I	II	IIIa/IIIb	I	II	IIIa/IIIb		
≤50	0,2	0,6	0,8	1,1	1,4	1,6	1,8	N/A	
>50 and ≤125	0,3	0,7	1,0	1,4	1,8	2,0	2,2	N/A	



>125 and ≤250	0,4	1,0	1,4	<u>2,0</u>	2,5	2,8	3,2	P
>250 and ≤400	0,8	1,6	2,2	3,2	4,0	4,5	5,0	N/A
>400 and ≤500	1,0	2,0	2,8	4,0	5,0	5,6	6,3	N/A
>500 and ≤800	1,8	3,2	4,5	6,3	8,0	9,0	10,0	N/A
>800 and ≤1000	2,4	4,0	5,6	8,0	10,0	11,0	12,5	N/A
>1000 and ≤1250	3,2	5,0	7,1	10,0	12,5	14,0	16,0	N/A
>1250 and ≤1600	4,2	6,3	9,0	12,5	16,0	18,0	20,0	N/A
>1600 and ≤2000	5,6	8,0	11,0	16,0	20,0	22,0	25,0	N/A
>2000 and ≤2500	7,5	10,0	14,0	20,0	25,0	28,0	32,0	N/A
>2500 and ≤3200	10,0	12,5	18,0	25,0	32,0	36,0	40,0	N/A
>3200 and ≤4000	12,5	16,0	22,0	32,0	40,0	45,0	50,0	N/A
>4000 and ≤5000	16,0	20,0	28,0	40,0	50,0	56,0	63,0	N/A
>5000 and ≤6300	20,0	25,0	36,0	50,0	63,0	71,0	80,0	N/A
>6300 and ≤8000	25,0	32,0	45,0	63,0	80,0	90,0	100,0	N/A
>8000 and ≤10000	32,0	40,0	56,0	80,0	100,0	110,0	125,0	N/A
>10000 and ≤12500	40,0	50,0	71,0	100,0	125,0	140,0	160,0	N/A

30.1	TABLE: Ball pressure			P
Part	Test temperature (°C)	Impression diameter (mm)	Allowed impression diameter (mm)	
Enclosure	75	1.2	2.0	
AC connector	125	1.2	2.0	

30.2	TABLE: Glow-wire		P
Part	Test temperature (°C)	Verdict	
Enclosure	550	No ignition	
AC connector	850	No ignition	

IEC/EN 60335-1			
Clause	Requirement + Test	Result - Remark	Verdict
Group/CENELEC Common Differences to IEC 60335-1:2001 (4. Edition)			
6.1	Delete "class 0" and "class 01"		P
7.1	Single-phase appliances to be connected to the supply mains: 230 V covered		P
	Multi-phase appliances to be connected to the supply mains: 400 V covered		N/A
25.6	Supply cords of single-phase portable appliances having a rated current not exceeding 16 A, fitted with a plug complying with the following standard sheets of IEC 60083:1975:		
	- for Class I appliances: standard sheet C2b, C3b or C4		N/A
	- for Class II appliances: standard sheet C5 or C6..:		P
25.7	Additional type of supply cord:		
	- ordinary polychloroprene sheathed flexible cord (60245 IEC 57)		N/A
25.7	Supply cords having high flexibility, not lighter than:		
	- rubber insulated and sheathed cord (60245 IEC 86)		N/A
	- rubber insulated, crosslinked PVC sheathed cord (60245 IEC 87)		N/A
	- crosslinked PVC insulated and sheathed cord (60245 IEC 88)		N/A
29.3	The third dashed item replaced by: - an assessment of the thermal quality of the material combined with an electric strength test, in accordance with 29.3.3, and, for accessible reinforced insulation consisting of a single layer, measurement in accordance with 29.3.Z1		N/A
29.3.Z1	For accessible reinforced insulation consisting of a single layer, the thickness of the layer complies with table Z1; rated voltage (V); overvoltage category; thickness (mm)		N/A
Annex ZC	ANNEX ZC (NORMATIVE) NORMATIVE REFERENCES TO INTERNATIONAL PUBLICATIONS WITH THEIR CORRESPONDING EUROPEAN PUBLICATIONS		
	A list of referenced documents in this standard		P
Annex ZD	ANNEX ZD (INFORMATIVE) IEC and CENELEC CODE DESIGNATIONS FOR FLEXIBLE CORDS		
	A list of code designations for different types of flexible cords		P

IEC/EN 60335-1			
Clause	Requirement + Test	Result - Remark	Verdict

National Differences for Austria			
25.6	Plugs according to standard sheet C3b not allowed		N/A

National Differences for Belgium			
25.6	Plugs according to standard sheet C2b not allowed		N/A

National Differences for Denmark			
7.12	Requirements regarding marking tag of power supply cord and connection of earthing wire for class I appliances delivered without a plug		N/A
25.6	Supply cords of single-phase portable appliances having a rated current not exceeding 13 A provided with a plug according to the following:		N/A
	Class I appliances: Section 107-2-D1, ed.3 1998, Standard Sheet DK 2-1a		N/A
	For appliances covered by a Part 2 of EN 60335, also plugs in accordance with Section 107-2-D1, ed. 3, 1998, Standard Sheet C2b, C3b or C4 are allowed		N/A
	Class II appliances: Section 107-2-D1, ed.3 1998, Standard Sheet C1b, C5, C6, DKA 2-1a and DKA 2-1b		N/A
	Stationary single-phase appliances, having a rated current not exceeding 13 A, and provided with a supply cord and a plug, the plug is in accordance with the requirements above		N/A
	Multi-phase appliances and single-phase appliances having a rated current exceeding 13 A, and provided with a supply cord and a plug, the plug is in accordance with the requirements below:		N/A
	Class I appliances: Section 107-2-D1, Standard Sheet DK 6-1a / EN 60309-2, Standard Sheet 2-II, 2-IV		N/A
	Class II appliances: Section 107-2-D1, Standard Sheet DK 6-1a / EN 60309-2, Standard Sheet 2-II, 2-IV, the earthing contact not being connected		N/A
	The current for the plug not exceeding the values specified; standard sheet (no.); current (A)		N/A

IEC/EN 60335-1			
Clause	Requirement + Test	Result - Remark	Verdict

National Differences for Finland			
25.6	Plugs according to standard sheet C3b not allowed		N/A

National Differences for France			
22.2	The second paragraph of this subclause, dealing with single-phase, permanently connected class I appliances having heating elements, is not applicable due to the supply system		N/A
25.6	Plugs according to standard sheet C2b not allowed		N/A

National Differences for Germany			
25.6	Plugs according to standard sheet C3b not allowed		N/A
29.3	Third dashed item not applicable for appliances where the insulation is accessible. Additional measures, such as a multi-layered insulation or adequate thickness, taken.		N/A

National Differences for Iceland			
25.6	Plugs according to standard sheet C3b not allowed		N/A

National Differences for Ireland			
25.6	Plugs according to standard sheet C3b not allowed		N/A
25.6	Only plugs according to Standard Sheets B2 and C5 allowed		N/A
25.6	These regulations apply to all plugs for domestic use at a voltage of not less than 200 V and allow only plugs complying with I.S. 401:1997, or equivalent, to be fitted to domestic appliances.		N/A
25.8	Replacement of figures (rated current/cross-sectional area) in the table		N/A

IEC/EN 60335-1			
Clause	Requirement + Test	Result - Remark	Verdict

National Differences for Italy			
7.1	The voltage is 220 V/380 V		N/A
25.6	Plugs according to standard sheet C3b not allowed		N/A
25.6	Only plugs listed in CENELEC Report R0BT-005:2001 allowed		N/A

National Differences for Luxembourg			
25.6	Plugs according to standard sheet C3b not allowed		N/A

National Differences for Netherlands			
25.6	Plugs according to standard sheet C3b not allowed		N/A

National Differences for Norway			
19.5	The test is also applicable to appliances intended to be permanently connected to fixed wiring		N/A
22.2	The second paragraph of this subclause, dealing with single-phase, permanently connected class I appliances having heating elements, is not applicable due to the supply system		N/A
25.6	Plugs according to standard sheet C3b not allowed		N/A

National Differences for Portugal			
25.6	Plugs according to standard sheet C3b not allowed		N/A

National Differences for Spain			
25.6	Plugs according to standard sheet C2b not allowed		N/A
25.6	Plugs according to standard sheet C3b not allowed		N/A
25.6	For appliances for household use, only the following plugs are allowed:		N/A
	according to UNE 20315: ESC 10-1b, C2b, C4, C6 or ESB 25-5b		N/A
	according to UNE-EN 50075		N/A

IEC/EN 60335-1			
Clause	Requirement + Test	Result - Remark	Verdict

National Differences for Sweden			
25.6	Plugs according to standard sheet C3b not allowed		N/A

National Differences for Switzerland			
4	Information about batteries with carbon-zinc and alkali-manganese		N/A
25.6	Plugs according to standard sheet C3b not allowed		N/A
25.6	Supply cords of portable household and similar electrical appliances having a rated current not exceeding 10 A, provided with a plug complying with SEV 1011 or IEC 60884-1 and one of the following dimension sheets:		N/A
	SEV 6532-2.1991, plug type 15, 3P+N/A+PE, 250/400 V, 10 A		N/A
	SEV 6533-2.1991, plug type 11, L+N/A, 250 V, 10 A		N/A
	SEV 6534-2.1991 plug type 12, L+N/A+PE, 250 V, 10 A		N/A

National Differences for United Kingdom			
25.6	Plugs according to standard sheet C2b not allowed		N/A
25.6	Plugs according to standard sheet C3b not allowed		N/A
25.6	Only plugs according to Standard Sheets B2 and C5 allowed		N/A
25.6	These regulations apply to all plugs for domestic use at a voltage of not less than 200 V and allow only plugs to BS 1363 to be fitted to domestic appliances. It also allows plugs to BS 4573 and standard sheet C5 to be fitted to shavers and toothbrushes.		N/A
25.8	Replacement of figures (rated current/cross-sectional area) in the table		N/A

APPENDIX No1: Circuit diagram and photographs

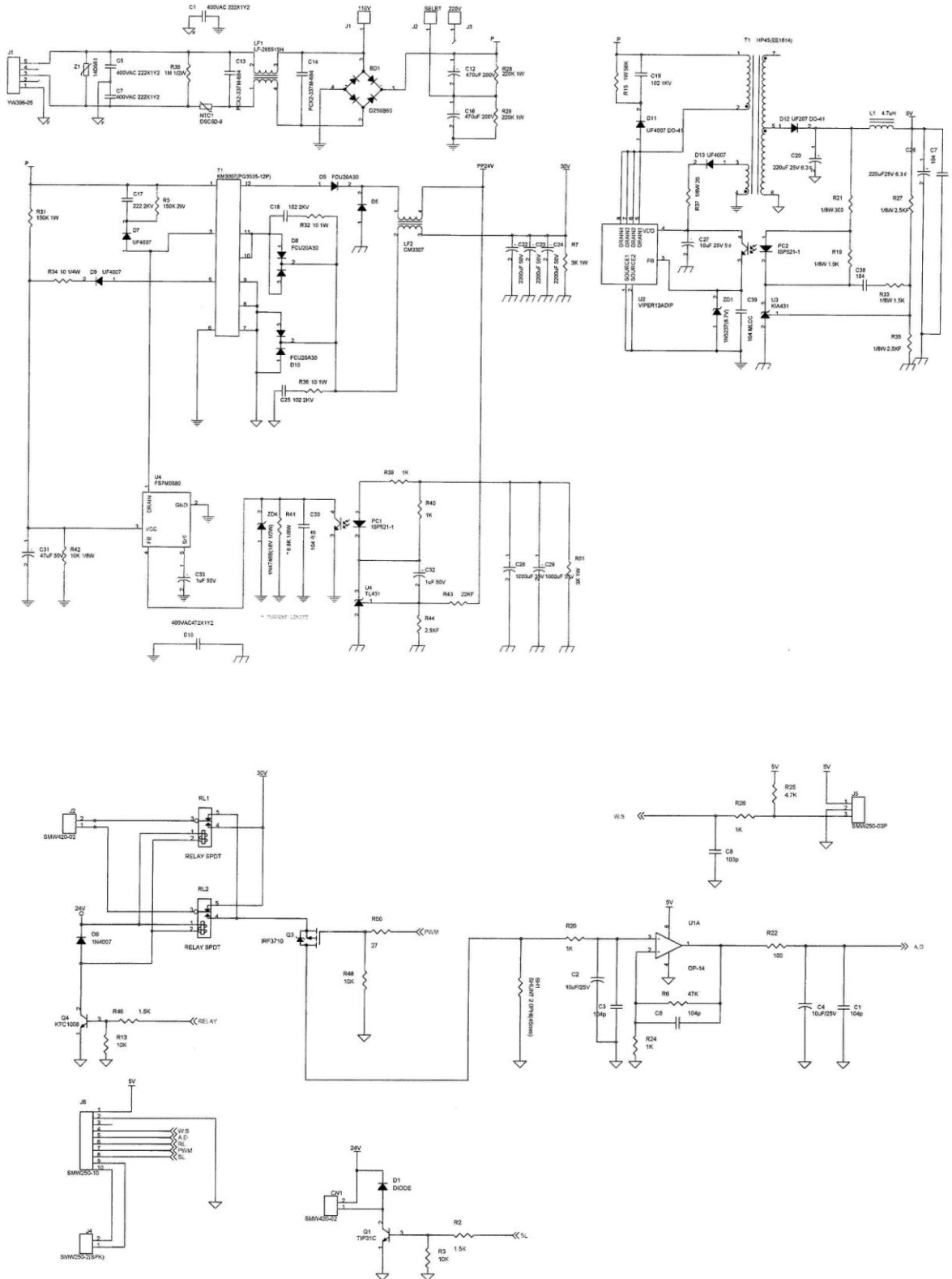



Front view



Rear view

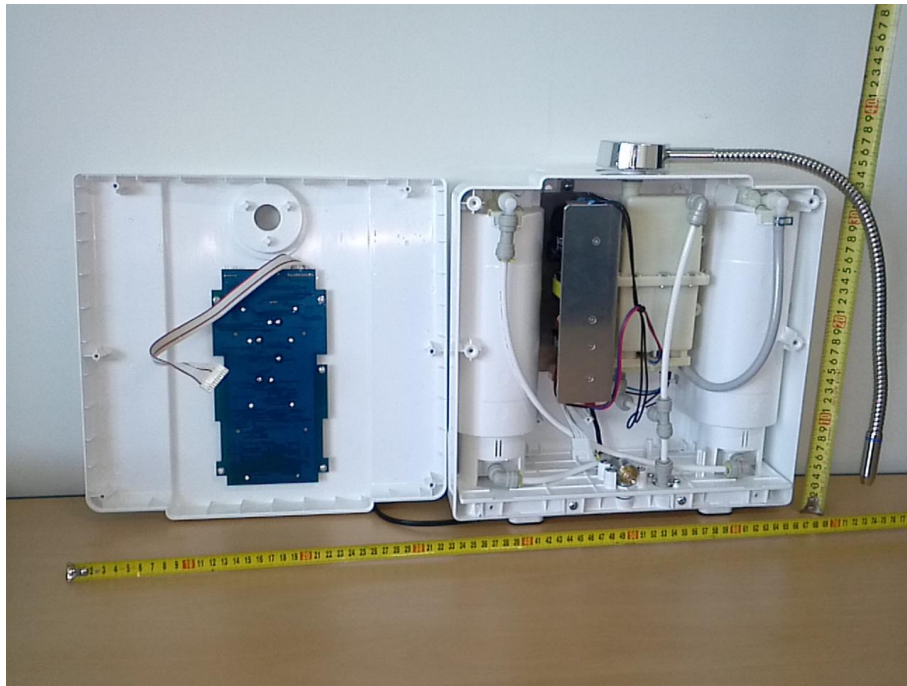

Internal view

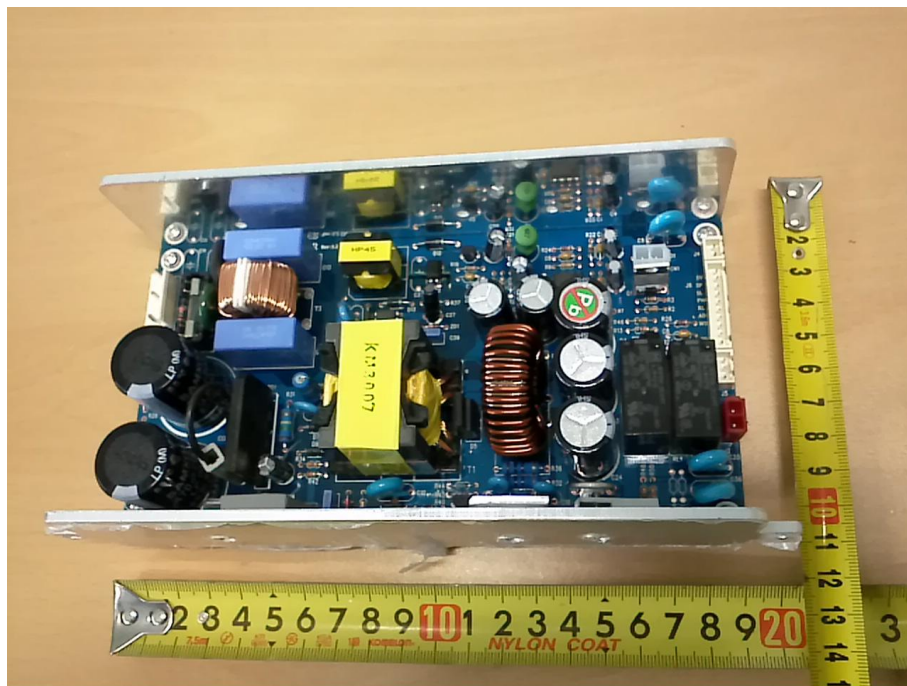

SMPS incorporating heat-sink

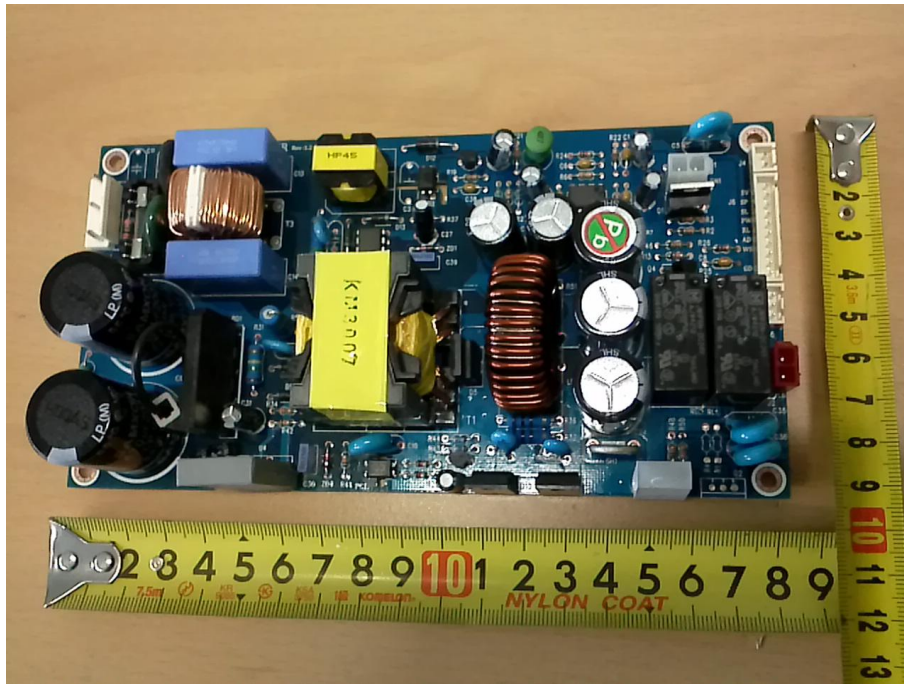

SMPS (Component side)

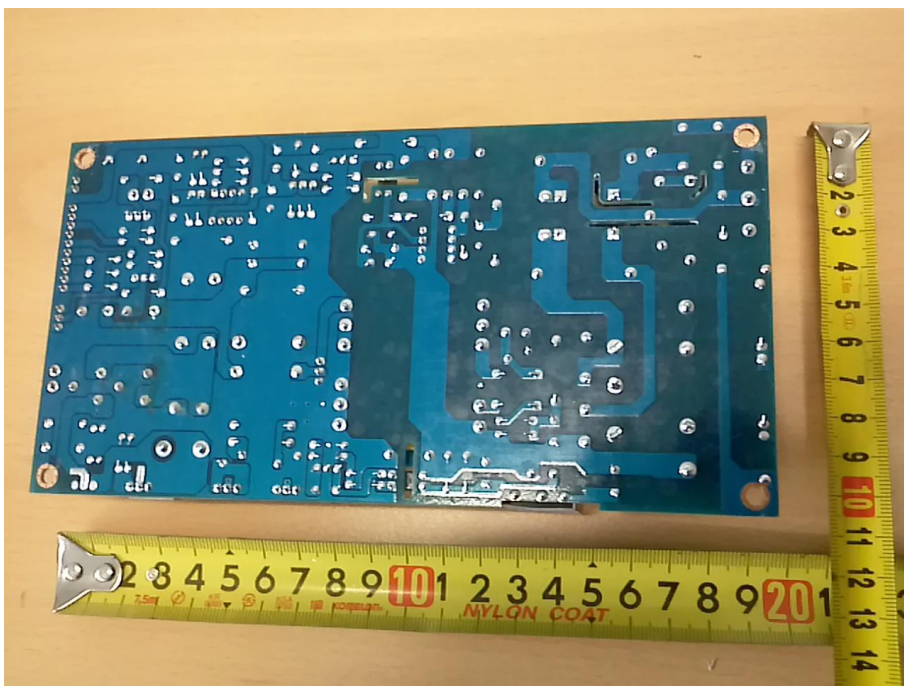

SMPS (Solder side)

Appendix 2: Amendment A13:2008 to EN 60335-1:2002			
24			-
24.1.7	Replace by:		N/A
	<i>If the remote operation of the appliance is via a telecommunication network, the relevant standards for the telecommunication interface circuitry in the appliance are EN 41003 and EN 60950-1:2006, Subclause 6.3</i>		N/A

Appendix 3.

Amendment A14:2010 to EN 60335-1:2002

**Household and similar electrical appliances –Safety
Part 1: General requirements**

Attachment contains

Cover page:	1 page
Requirements:	5 pages
Total:	6 pages

Explanation for Abbreviations:

Possible Verdicts: **P** = Pass, **F**= Fail, **N/A** = Not Applicable

Remarks:

Throughout this report, a comma is used as the decimal separator.

Amendment A14:2010 to EN 60335-1:2002			
Clause	Requirement –Test	Result - Remark	Verdict
ZE	ANNEX ZE (INFORMATIVE)		N/A
	SPECIFIC ADDITIONAL REQUIREMENTS FOR APPLIANCES AND MACHINES INTENDED FOR COMMERCIAL USE		N/A
7.1	Business name and full address of the manufacturer and, where applicable, his authorized representative		N/A
	Model or type reference.....		N/A
	Serial number, if any.....		N/A
	Production year		N/A
	Designation of the appliance.....		N/A
7.12	Instructions provided with the appliance so that the appliance can be used safely		N/A
	The instructions contain at least the following information:		N/A
	- the business name and full address of the manufacturer and, where applicable, his authorized representative		N/A
	- model or type reference of the appliance as marked on the appliance itself, except for the serial number		N/A
	- the designation of the appliance together with its explanation in case it is given by a combination of letters and/or numbers		N/A
	- the general description of the appliance, when needed due to the complexity of the appliance		N/A
	- specific precautions if required during installation, operation, adjusting, user maintenance, cleaning, repairing or moving		N/A
	- when needed drawings, diagrams, descriptions and explanations necessary for the safe use and user maintenance of the appliance		N/A
	- the possible reasonably foreseeable misuse and, whenever relevant, a warning against the effects it may have on the safe use of the appliance		N/A
	The words “Original instructions” appear on the language version(s) verified by the manufacturer or by the authorized representative		N/A
	When a translation of the original instructions has been provided by a person introducing the appliance on the market; the meaning of the sentence “Translation of the original instructions” appear in the relevant instructions delivered with the appliance		N/A
	The instructions for maintenance/service to be done by specialized personnel, mandated by the manufacturer or the authorized representative may be supplied in only one Community language which the specialized personnel understand		N/A

Amendment A14:2010 to EN 60335-1:2002			
Clause	Requirement –Test	Result - Remark	Verdict
	The instructions indicate the type and frequency of inspections and maintenance required for safe operation including the preventive maintenance measures		N/A
7.12.Z1	Wherever needed for specific appliances, the following information to be given:		—
	- on use, transportation, assembly, dismantling when out of service, testing or foreseeable breakdowns, if these operations have consequences on stability of the appliance in order to avoid overturning, falling or uncontrolled movements of the appliance or of its component parts		N/A
	- on how to maintain adequate mechanical stability when in use, during transportation, assembly, dismantling, scrapping and any other action involving the appliance		N/A
	- on the protective measures to be taken by the user, including, where appropriate, the personal protective equipment to be provided		N/A
	- on the operating method to be followed in the event of accident or breakdown; if a blockage is likely to occur the operating method to safely unblock the appliance		N/A
	- on the specifications on the spare parts to be used, when these affect the health and safety of the operator		N/A
	- on airborne noise emissions, determined and declared in accordance with the relevant Part 2		N/A
	This includes:		—
	- the A-weighted emission sound pressure level at workstations, where this exceeds 70 dB(A) ;		N/A
	- where this level does not exceed 70 dB(A), this fact is indicated		N/A
	- the peak C-weighted instantaneous sound pressure value at workstations, where this exceeds 63 Pa (130 dB in relation to 20 µPa) :		N/A
	- the A-weighted sound power level emitted by the machinery, where the A-weighted emission sound pressure level at workstations exceeds 80 dB(A) :		N/A
19.11.4.8	The appliance continues to operate, without causing any hazard to the user, from the same point in its operating cycle at which the voltage fluctuation occurred, or		N/A
	a manual operation is required to restart it		N/A
20.1	Appliances and their components and fittings have adequate mechanical stability during transportation, assembly, dismantling and any other action involving the appliance		N/A
20.2	Dangerous moving transmission parts safeguarded either by design or guards		N/A

Amendment A14:2010 to EN 60335-1:2002			
Clause	Requirement –Test	Result - Remark	Verdict
	When guards are used, they are fixed guards, interlocking movable guards or protective devices		N/A
	Moving parts directly involved in the function of the appliance which cannot be made completely inaccessible fitted with:		—
	- fixed guards or interlocking movable guards preventing access to those sections of the parts that are not used in the work, and		N/A
	- adjustable guards restricting access to those sections of the moving parts where access is necessary		N/A
	Interlocking movable guards used where frequent access is required		N/A
21.1	Appliances and their components and fittings have adequate mechanical strength and is constructed to withstand such rough handling that may be expected in normal use, during transportation, assembly, dismantling, scrapping and any other action involving the appliance		N/A
22.ZE.1	For appliances provided with a seat, the seat gives adequate stability		N/A
	The distance between the seat and the control devices capable of being adapted to the operator		N/A
22.ZE.2	For appliances provided with separate devices for the start and the stop functions, the stop function is unambiguously identifiable and does always override the start function		N/A
	For appliances provided with one device performing the start and the stop function, the stop function is unambiguously identifiable and does always override the start function		N/A
22.ZE.3	Appliances designed in such a way that incorrect mounting is avoided, if this can lead to an unsafe situation		N/A
	If this is not possible, information on the correct mounting is given directly on the part and/or the enclosure		N/A
22.ZE.4	Where the weight, size or shape prevents appliances from being moved manually, they are fitted with attachments for lifting gear, or		N/A
	so designed that they can be fitted with such attachments, or		N/A
	be shaped in such a way that standard lifting gear can easily be used		N/A
	Appliances to be moved manually are constructed or equipped so that they can be moved easily and safely		N/A
22.ZE.5	The fixing systems of fixed guards which prevent access to dangerous moving transmission parts only removable with the use of tools		N/A
	If such guards have to be removed frequently their fixing systems remain attached to the fixed guards or to the machine after removal		N/A

Amendment A14:2010 to EN 60335-1:2002			
Clause	Requirement –Test	Result - Remark	Verdict
	Where possible, guards are incapable of remaining in place without their fixings		N/A
	This does not apply if, after removal of the screws, or if the component is incorrectly repositioned, the appliance becomes inoperative		N/A
	If movable guards are interlocked, the interlocking devices prevent the start of hazardous appliance functions until the guards are fixed in their position, and give a stop command whenever they are no longer closed		N/A
	Where it is possible for an operator to reach the danger zone before the risk due to hazardous appliance functions has ceased, movable guards associated with a guard locking device in addition to an interlocking device that:		—
	- prevents the start of hazardous appliance functions until the guard is closed and locked, and		N/A
	- keeps the guard closed and locked until the risk of injury from the hazardous appliance functions has ceased		N/A
	Interlocking movable guards remain attached to the appliance when open and they are designed and constructed in such a way that they can be adjusted only by means of an intentional action		N/A
	Interlocking movable guards designed in such a way that the absence or failure of one of their components prevents starting or stops the hazardous appliance functions		N/A
	Compliance is checked by inspection and by the tests as specified		N/A
	After this test any defect that may be expected in normal use is applied to the interlock system, including interruption of the supply, only one defect being simulated at a time		N/A
	After these tests the interlock system is fit for further use		N/A
	Adjustable guards restricting access to those areas of the moving parts strictly necessary for the work are:		—
	- adjustable manually or automatically, depending on the type of work involved, and		N/A
	- readily adjustable without the use of tools		N/A
22.ZE.6	In case of interruption, re-establishment after an interruption or fluctuation in whatever manner of the power supply, the appliance does not restart		N/A
	However, automatic restarting of the operation is allowed if the appliance may continue to operate, without causing any hazard to the user, from the same point in its operating cycle at which the voltage interruption or fluctuation occurred		N/A
ZF	ANNEX ZF (INFORMATIVE)		—
	CRITERIA APPLIED FOR THE ALLOCATION OF PRODUCTS COVERED BY STANDARDS IN THE EN 60335 SERIES UNDER LVD OR MD		—

Amendment A14:2010 to EN 60335-1:2002			
Clause	Requirement –Test	Result - Remark	Verdict
	A list of standards under CENELEC/TC61 with the consequent allocation of standards under LVD or MD		P
ZZ	ANNEX ZZ (INFORMATIVE)		—
	COVERAGE OF ESSENTIAL REQUIREMENTS OF EC DIRECTIVES		—
	Description of the background for the European standard EN 60335-1/A14:2010		P